



## Fort Myers Beach Special Magistrate Hearing

Town Hall Council Chambers  
6231 Estero Boulevard  
Fort Myers Beach, FL 33931  
Tuesday, March 3, 2026

Agenda

9:00 AM

### ORDER OF BUSINESS

**I. CALL TO ORDER**

**II. APPROVAL OF MINUTES**

A. January 6, 2026

**III. VIOLATION CASES**

A. FMB Case # 20240733

**Property Owner: Midwest Decoration Co**

**FMB Case # 20240733**

**Property Address: 146 Hercules Dr**

**Violation: Interior and Exterior remodel exceeding the scope of the permit and expired permit 234613**

**Officer: M. Hauserman**

**Request to Continue to May 5, 2026 Hearings**

B. FMB Case # 20250800

**Property Owner: B + B Properties of Fort Myers, LLC (The Beach Bar)**

**FMB Case # 20250800**

**Property Address: 1668 I Street**

**Violation: Lack of current valid building permit and building code deficiencies.**

**Officer: M. Hauserman**

**Request to Continue to May 5, 2026 Hearings (Working with Building Department)**

C. FMB Case # 20250802

**Property Owner: Bryan G & Christine Dawn Thomas**

**FMB Case # 20250802**

**Property Address: 263 Palermo Circle**

**Violation: Lack of current valid building permit and building code deficiencies.**

**Officer: M. Hauserman**

**Request to Continue to August 5, 2026 Hearings**

**IV. STATUS UPDATE (FINES ASSESMENTS)**

A. FMB Case # 20250819

**COMPLIANT**

Property Owner: John Daniels  
Property Address: 250/252 Bahia Via  
Violation: Work without permits  
Officer: M. Hauserman

B. FMB Case # 20250853

**COMPLIANT - ADMINISTRATIVE COSTS PAID  
CASE CLOSED**

Property Owner: Adrienne Turner  
Property Address: 12 Fairview Blvd  
Violation: Work without permits  
Officer: M. Hauserman

**V. CERTIFICATION OF LIEN(S) (NON-COMPLIANCE)**

**VI. LIEN FORECLOSURE CASES**

**VII. BUILDING OFFICIAL APPEALS**

**VIII. ADJOURNMENT**

**NOTE: THIS MEETING IS STREAMED LIVE ON YOUTUBE.**

**IF A PERSON DECIDES TO APPEAL A DECISION MADE BY THE SPECIAL MAGISTRATE IN ANY MATTER CONSIDERED AT THIS HEARING, SUCH PERSONS MAY NEED TO ENSURE THAT A VERBATIM RECORD OF THE PROCEEDING IS MADE, TO INCLUDE THE TESTIMONY AND EVIDENCE UPON WHICH ANY SUCH APPEAL IS TO BE BASED.**



**For special accommodation, please notify the Town Clerk's Office at least 72 hours in advance. (239) 765-0202**

In accordance with the Americans with Disabilities Act (ADA), persons needing a special accommodation to participate in the Board's proceedings should contact the Town Clerk's Office not later than three days prior to the proceedings.



## Fort Myers Beach Special Magistrate Hearing

Town Hall Council Chambers  
6231 Estero Boulevard  
Fort Myers Beach, FL 33931

Minutes

Tuesday, January 6, 2026

9:00 AM

DRAFT

### ORDER OF BUSINESS

#### I. CALL TO ORDER

Members present: Code Enforcement Manager Michael Hauserman and Special Magistrate John Van Lanningham.

#### II. APPROVAL OF MINUTES

A. December 4, 2025

Special Magistrate Van Laningham approved the minutes.

#### III. VIOLATION CASES

A. FMB Case # 20251060

**Property Owner: Danny Lewis & Carol Jean Thomas**

**Property Address: 151 Miramar St**

**Violation: Work without permits. Plumbing not in compliance with the code.**

**Officer: M. Hauserman**

Manager Hauserman noted that Exhibits 1–14 were not authenticated by the permit records. Floodplain Manager Kelli DeFedericis stated that she had not found any records showing that the ground floor was legally permitted. A permit was received for doors and windows in 2023. They did a revision to remodel the ground floor, but it was not permitted.

Carol Jean Thomas described Exhibits 13 and 14, which were included in the agenda packet. She asked Manager DeFedericis several questions and whether she could prove that the ground floor bathroom was not permitted.

Manager DeFedericis repeated that they could not find any records. Ms. Thomas listed people she called for information regarding the definition of a ground floor. A discussion ensued about where her records were. Manager Hauserman objected to hearsay.

Ms. Thomas discussed Exhibit 9 regarding a finished lower level. Manager DeFedericis noted that the property appraiser did not have a record of Ms. Thomas having a bathroom on the ground floor. Ms. Thomas referred to

Exhibit 13, page 38, which showed a diagram of a bathroom, a kitchen, and a laundry area. She described Exhibit 12 and discussed Ordinance 34-3201 regarding a non-conforming use. Ms. Thomas did not have an official document stating that her property met the ordinance's qualifications. She indicated that Mr. Shocki reviewed everything, including the appraisal, and that there were 1.5 baths on the upper level and 1 bath on the ground floor.

The 2023 permit revision in Exhibit 7 showed the lower level with a bathroom and a kitchenette. Manager DeFedericis noted that no permit had been issued. Ms. Thomas pointed out that the permit in Exhibit 8 noted the work had been completed and was closed. Manager DeFedericis replied that the certificate of completion was rescinded. Ms. Thomas pointed to a permit issued on September 10, 2025, that noted the kitchenette and bathroom were approved in the revision and that the permit was finalized. Manager DeFedericis replied that the revision permit was never approved.

Patricia Smith from New Jersey appeared on Zoom. She testified that in 1980, her mother owned the house at 81 Miramar and added a bathroom, a laundry area, and a water heater in the lower level. Manager Hauserman asked if Ms. Smith was aware of any permits for the plumbing and bathroom. She replied negatively.

Ms. Thomas believed she had proved that a bathroom existed in the lower level and summarized her testimony. She stated that it was not her fault that there were no records before 1986 and asked the court to rule in her favor. Ms. DeFedericis noted that FEMA requested proof that the ground floor could be converted.

Special Magistrate Van Laningham said that no one disputed that the plumbing had been there for years.

Ms. Thomas stated that she purchased her home in 2021 as a four-bedroom, 3 1/2-bath home. Removing the lower level devalued her home.

The town requested that a violation existed and to give the property owner 60 days to come into compliance or a daily fine of \$250.00 plus administrative costs of \$250.00. The property owner would have to remove all unpermitted construction, including the plumbing, to come into compliance.

Special Magistrate Van Laningham requested that both parties submit proposed orders within a week so he can review the written arguments. Ms. Thomas asked to submit the order within two weeks. Special Magistrate Van Laningham agreed. The deadline for the proposed orders is January 20, 2026.

B. FMB Case # 20240733

**Rescheduled to March 2026**

**Property Owner: Midwest Decoration Co**

**Property Address: 146 Hercules Dr**

**Violation: Interior and exterior remodel exceeding the scope of the permit and expired permit #234613.**

**Officer: M. Hauserman**

- C. FMB Case # 20250800  
**Rescheduled to March 2026**  
**Property Owner: B + B Properties of Fort Myers, LLC (The Beach Bar)**  
**Property Address: 1668 I Street**  
**Violation: Lack of current valid building permit and building code deficiencies.**  
**Officer: M. Hauserman**
- D. FMB Case # 20250802  
**Rescheduled to March 2026**  
**FMB Case # 20250802**  
**Property Owner: Bryan G & Christine Dawn Thomas**  
**Property Address: 263 Palermo Circle**  
**Violation: Lack of current valid building permit and building code deficiencies.**  
**Officer: M. Hauserman**

#### IV. STATUS UPDATE (FINES ASSESMENTS)

- A. FMB Case# 20250819  
**Property Owner: John Daniels**  
**Property Address: 250/252 Bahia Via**  
**Violation: Work without permits.**  
**Officer: M. Hauserman**  
Manager Hauserman noted that on December 3, 2025, the violation still existed and he did not obtain the required permits. He submitted the documentation as Packet A.  
Joseph Daniels, son of Mr. Daniels, commented that not much progress has been made. He was working with Ms. DeFedericis regarding a discrepancy between the cost breakdown provided and the policy payout. He has not submitted a response yet and has requested a week to gather the information for her. Ms. DeFedericis did not object to giving him an extra week, and Manager Hauserman agreed to extend the compliance date to January 20, 2026. Special Magistrate stated that administrative fees of \$250.00 will be assessed.
- B. FMB Case # 20250853  
**Property Owner: Adrienne Turner**  
**Property Address: 12 Fairview Blvd**  
**Violation: Work without permit**  
**Officer: M. Hauserman**  
Manager Hauserman noted that permits were obtained on December 12, 2025, and documents were filed on December 18, 2025, with a compliance date of December 12, 2025. Mr. Hauserman agreed to waive the fine, but

the \$250.00 administrative fee remained due.

C. FMB Case # 20250988

**Property Owner: Tiva Invest Real LLC**

**Property Address: 8010 Estero Blvd**

**Violation: Work without permit**

**Officer: M. Hauserman**

Manager Hauserman reported that an affidavit of non-compliance was filed on December 8, 2025. The town has been working with this property owner, who lives out of the country and has a language barrier. Manager Hauserman requested an extension of the compliance date to January 30, 2026, for reinspection. Special Magistrate Van Laningham agreed.

D. FMB Case # 20250811

**Property Owner: Mark & Sheri Brooks**

**Property Address: 7846 Buccaneer Dr.**

**Violation: Work without permit**

**Officer: M. Hauserman**

Manager Hauserman noted that a copy of the order and affidavit of compliance was submitted as Exhibit A, showing compliance on December 4, 2025. Special Magistrate Van Laningham ordered administrative costs of \$250.00.

**V. CERTIFICATION OF LIEN(S) (NON-COMPLIANCE)**

No liens.

**VI. LIEN FORECLOSURE CASES**

No cases.

**VII. BUILDING OFFICIAL APPEALS**

No appeals.

**VIII. ADJOURNMENT**

Special Magistrate Van Laningham adjourned the hearing.

**Property Address and Owner:**

**Hearing Date: March 3, 2026**

Property Owner: Midwest Decoration Co  
FMB Case # 20240733

Property Address: 146 Hercules Dr

Violation: Interior and Exterior remodel exceeding the scope of the permit and expired permit  
234613

Officer: M. Hauserman

Request to Continue to May 5, 2026 Hearings

**Subject:**

**Code Section:**

**Reference Number:**

**Strap Number:**

**Officer:**

---

**Narrative:**

Permit submitted and under review.

**Attachments:**

1. 20240733\_146 Hercules Dr\_ Exhibit A\_Historical Notices Service Ownership and Evidence
2. 20240733\_146 Hercules Dr\_ Exhibit B\_Current Notice of Violation and Hearing Affidavit of Service Proof of Service Proof of Ownership
3. 20240733\_146 Hercules Dr\_ Draft Notice of Continued Hearing

**Town Recommendations:**

**Town Approvals:**

\_\_\_\_\_  
Michael Hauserman, Code Compliance Manager

Date: February 25, 2026

\_\_\_\_\_  
Thomas Yozzo, Emergency Services Director

Date: February 25, 2026



\_\_\_\_\_  
Traci Kohler, Deputy Town Manager

Date: February 25, 2026

\_\_\_\_\_  
nancy stuparich, Town Attorney

Date: February 25, 2026

\_\_\_\_\_  
Lizzette Roman, Town Clerk Administrative Coordinator

Date: February 25, 2026

\_\_\_\_\_  
Amy Baker, Town Clerk

Date: February 25, 2026

# EXHIBIT A

- Notice of Violation & Hearing
- Evidence of Service
  - Affidavit of Positing
  - Evidence of Posting at violation address
  - Evidence of Posting at Town Hall
  - Evidence of Mailing / Certified Mail
- Evidence of Ownership
  - Lee County Property Appraisers
  - Tax Bill
- Initial Inspection Evidence
  - Photographs
  - Permit records
  - Other Evidence



Town of Fort Myers Beach

6231 Estero Blvd, Florida 33931  
Phone: 239-765-0202 Fax: 239-765-0909

TOWN OF FORT MYERS BEACH,  
FLORIDA,

Petitioner,  
vs.

Case #:	20240733
Certified Mail:	9589071052713142142185 9589071052703142142178
Regular Mail:	USPS 11/14/2025

Midwest Decoration Co.  
Respondent.

\_\_\_\_\_ /

AFFIDAVIT OF NOTICE AND POSTING

STATE OF FLORIDA  
COUNTY OF LEE

BEFORE ME, the undersigned authority, personally appeared Michael J Hauserman, who being duly sworn by me, on oath, deposes and says the following regarding that certain Notice of Violation and Notice of Hearing attached hereto as **Exhibit A** (“the Notice”):

1. My name is Michael J Hauserman. I am over 18 years of age and am competent to testify to the matters set forth herein. I make this Affidavit based upon my personal knowledge.
2. I am employed as the Code Compliance Manager for the Town of Fort Myers Beach (“Town”).
3. On 11/14/2025, I personally mailed a copy of the Notice by certified mail and first-class mail as follows:
  - a. To the property owner at the address listed in the records of the Lee County Tax Collector and/or Lee County Property Appraiser for tax notices, which address is: 15214 Tonkel Road, Leo, IN 46765. A true and correct copy of the property ownership and address information obtained from the Tax Collector/Property Appraiser is attached hereto as **Exhibit A**. A copy of the certified mail receipt is attached hereto as **Exhibit A**.

- b. To the following additional address(es) reasonably believed to be valid for the property owner: **Midwest Decoration Co.**. A copy of the certified mail receipt is attached hereto as **Exhibit A**.
- c. The property is owned by **Midwest Decoration Co.**, a business entity not registered in the State of Florida or the State of Indiana. I mailed a copy of the Notice by certified mail and first-class mail to the business at the following address: **15214 Tonkel Road, Leo IN 46765**. A copy of the certified mail receipt is attached hereto as **Exhibit A**. A true and correct copy of the Florida Division of Corporations record for the entity, identifying its Registered Agent, is attached hereto as **Exhibit A**.

4. On **11/14/2025**, I mailed via USPS regular mail and posted a copy of the Notice at **146 Hercules Drive, Fort Myers Beach, FL 33931**, which is the property upon which the violation is alleged to exist. Photographs of the posted Notice, taken by me on that date, are attached hereto as **Exhibit A**.

5. On **11/14/2025**, I posted a copy of the Notice at Town Hall, located at 6231 Estero Boulevard, Fort Myers Beach, FL 33931, which is the primary municipal government office for the Town of Fort Myers Beach. Photographs of the posted Notice, taken by me on that date, are attached hereto as **Exhibit A**.

Under penalties of perjury, I declare that I have read the foregoing Affidavit and that the facts stated in it are true and to the best of my knowledge and belief comply with Section 2-429 of the Town of Fort Myers Beach Land Development Code and Section 162.12, Florida Statutes.

**SWORN AND ATTESTED BY:**



**Signature of Affiant**  
**Printed Name: Michael J Hauserman**  
**Title: Code Compliance Manager**

The foregoing instrument was sworn to, subscribed and acknowledged before me by means of  physical presence /  online notarization, this 14 day of November, 2025 by Michael J Hauserman, who  is personally known to me  or has produced \_\_\_\_\_ as identification.



Notary Public, State of Florida  
Printed Name: Rileigh R Baker  
My Commission No.: HH 637224  
My Commission Expires: 2/5/2029

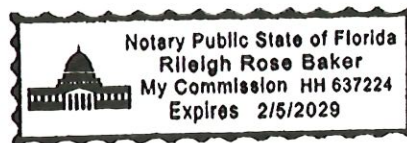



**Town of Fort Myers Beach**  
**NOTICE OF VIOLATION AND NOTICE OF CODE**  
**ENFORCEMENT HEARING**

6231 Estero Blvd, Fort Myers Beach, FL 33931  
Phone : (239) 765-0202

\*\*\*REISSUED\*\*\*

Date: November 14, 2025

Case Number: 20240733

Owner: **Midwest Decoration Co**

Mailing Address: 15214 Tonkel Road, Leo, IN 46765

Property Address: **146 Hercules Dr, Fort Myers Beach, FL 33931**

Certified Mail# 9589071052703142133961 & 9589071052703142172502

Parcel: 29-46-24-W2-0060A.0110

YOU ARE HEREBY NOTIFIED that the undersigned Code Officer alleges that on October 15, 2025 the following violation(s) of the Florida Building Code, Eighth Edition and the Land Development Code of the Town of Fort Myers Beach, Florida, existed on the property above:

**Code Violation:** On 10/15/2025, a violation was discovered Interior and Exterior remodel, exceed the scope of the approved permit 234613. Permit 234613 has expired thus leaving the construction work conducted without the required building permits as defined in Division 3 Section 6-111 (adoption; amendments) of the FMB Code of Ordinances in adoption of the Florida Building Code.

**Relevant Codes:**

**Sec. 6-111. - Adoption; amendments.**

The Florida Building Code is hereby adopted by reference and made a part of this article, including all revisions and amendments approved in accordance with state law, with the exceptions set forth as follows:

**2023 Florida Building Code, Building, Eighth Edition**

*FBC Sec 105.1 Permits required. Any owner or owner's authorized agent who intends to construct, enlarge, alter, repair, move, demolish or change the occupancy of a building or structure, or to erect, install, enlarge, alter, repair, remove, convert or replace any impact-resistant coverings, electrical, gas, mechanical or plumbing system, the installation of which is regulated by this code, or to cause any such work to be performed, shall first make application to the building official and obtain the required permit.*

*LDC Sec 6-441 – Any owner or owner's authorized agent (hereinafter "applicant") who intends to undertake any development activity within the scope of this article, including buildings, structures and facilities exempt from the Florida Building Code, which is wholly within or partially within any flood hazard area must first make application to the floodplain administrator, and the building official, if applicable, and must obtain the required permits and approvals. No*

*such permit or approval will be issued until compliance with the requirements of this article and all other applicable codes and regulations has been satisfied.*

*(Ord. No. 13-06, § 2, 9-3-2013; Ord. No. 16-02, § 2, 8-8-2016)*

**Corrective Action Required:**

The following action is required to bring the violation(s) into compliance. Obtain / reactivate the required building permits for the unpermitted construction or retore the structure to it's original permit condition.

**Compliance is required on or before: December 3, 2025**

If the referenced violations are corrected from the date of issuance of this notice, you must contact the (Emergency Services Director) Thomas Yozzo at (239) 765-0202 or (Code Manager) Michael Hauserman at (239) 478-9363

**A HEARING FOR THIS MATTER HAS BEEN SET BY THE SPECIAL MAGISTRATE CLERK FOR THE 7th DAY OF JANUARY 2026, AT 9:00 AM, AT 6231 ESTERO BLVD, FORT MYERS BEACH, FL 33931. (Fort Myers Beach Town Hall Council Chambers)**

Should all violations not be corrected and approved by the undersigned Code Enforcement Officer within the date and time specified above, you will be required to appear at the prosecution of this matter before the Town's Special Magistrate for Code Compliance, pursuant to Division 2 of Article V of Chapter 2 of the Town Land Development Code and Chapter 162, Florida Statutes. **THIS HEARING, REQUIRING YOU TO BE PRESENT, WILL BE HELD IF THE VIOLATION(S) HAVE NOT BEEN BROUGHT INTO COMPLIANCE AND APPROVED BY THE CODE ENFORCEMENT DEPARTMENT BY Wednesday, December 3, 2025 AS EVIDENCED BY THE ISSUANCE OF AN AFFIDAVIT OF COMPLIANCE BY THE CODE ENFORCEMENT OFFICER.** If a violation is corrected and then recurs, or if a violation is not corrected by the time specified for correction by the code inspector, the case may be presented to the Special Magistrate even if the violation has been corrected prior to the board hearing.

The Code Officer has reason to believe that the violation(s) or the condition causing the violation(s) presents a serious threat to the public health, safety, and welfare or is irreparable or irreversible in nature, and therefore, no compliance date has been provided. This case may be presented to the Special Magistrate even if the violation(s) have been corrected prior to the hearing.

The Code Officer has reason to believe that repeat violations have been found, and therefore, no compliance date has been provided. This case may be presented to the Special Magistrate even if the repeat violation(s) have been corrected prior to the hearing.

The purpose of this Hearing is for the Special Magistrate to make "Findings of Fact" and "Conclusions of Law" relating to the violation(s) specified in the attached Violation detail and to issue an appropriate Order. The Hearing is also your opportunity to present evidence and/or contest the alleged violations, should you wish to do so. If a violation is found, the Order may require you to correct the violation(s) by a specified date. In addition, the Order may impose daily fines as per Florida Statutes Section 162.09(2)(a) of the following:

- \$250/ day per violation
- \$500/day for repeat offenses
- \$5,000 for irreversible or irreparable violations

Additionally, administrative fines may be imposed to recover all costs incurred by the Town in prosecuting this matter. If all violations are not corrected prior to the Hearing date, you may be assessed any such costs. **THE IMPOSITION OF FINES AND/OR COSTS MAY RESULT IN A LIEN AGAINST YOU AND YOUR PROPERTY.**

You should be aware that if the alleged violation(s) is/are corrected prior to the Hearing and recurs within five (5) years from the date of the original Notice of Violation, the case may be presented to the Special Magistrate as a Recurring Violation even if the violation is subsequently corrected.

You have the right to be represented by an attorney and to respond and present evidence and witnesses at the Hearing. If you wish to be represented by an attorney, your attorney **MUST** notify the Special Magistrate's Clerk in writing at least five (5) working days before the Hearing.

You may also have other rights which are set forth in Division 2 of Article V of Chapter 2 of the Town Land Development Code. If a person decides to appeal any decision with respect to any matter considered at this Hearing, such person will need to ensure that a verbatim record of the proceedings is made, which includes the testimony and evidence upon which the appeal is to be based (Section 286.0105, Florida Statutes).

For additional HEARING information, contact the Town of Fort Myers Beach Special Magistrate Clerk at (239) 478-9363.

Michael J Hauserman, CEP



---

Signature of Affiant

Code Enforcement / Code Compliance Manager  
Fort Myers Beach, Florida

9589 0710 5270 3142 1421 85

U.S. Postal Service™ 20240733  
CERTIFIED MAIL® RECEIPT  
Domestic Mail Only

For delivery information, visit our website at [www.usps.com](http://www.usps.com)

OFFICIAL USE

Certified Mail Fee	\$
Extra Services & Fees (check box, add fee as appropriate)	
<input type="checkbox"/> Return Receipt (hardcopy)	\$
<input type="checkbox"/> Return Receipt (electronic)	\$
<input type="checkbox"/> Certified Mail Restricted Delivery	\$
<input type="checkbox"/> Adult Signature Required	\$
<input type="checkbox"/> Adult Signature Restricted Delivery	\$
Postage	\$
Total Postage and Fees	\$

Postmark  
Here

Sent To	Midwest Decoration Co
Street and Apt.	146 Hercules Dr
City, State, ZIP	Fort Myers Beach, FL 33931

PS Form 3800, January 2023 PSN 7530-02-000-9047 See Reverse for Instructions

9589 0710 5270 3142 1421 78

U.S. Postal Service™ 20240733  
CERTIFIED MAIL® RECEIPT  
Domestic Mail Only

For delivery information, visit our website at [www.usps.com](http://www.usps.com)

OFFICIAL USE

Certified Mail Fee	\$
Extra Services & Fees (check box, add fee as appropriate)	
<input type="checkbox"/> Return Receipt (hardcopy)	\$
<input type="checkbox"/> Return Receipt (electronic)	\$
<input type="checkbox"/> Certified Mail Restricted Delivery	\$
<input type="checkbox"/> Adult Signature Required	\$
<input type="checkbox"/> Adult Signature Restricted Delivery	\$
Postage	\$
Total Postage and Fees	\$

11-14-25  
Postmark  
Here  
MT

Sent To	Midwest Decoration Co
Street and Apt.	15214 Tonkel Rd
City, State, ZIP	Leo, IN 46765

PS Form 3800, January 2023 PSN 7530-02-000-9047 See Reverse for Instructions





City of Fort Myers Beach  
NOTICE OF VIOLATION AND NOTICE OF CODE  
ENFORCEMENT HEARING  
6231 Estero Blvd, Fort Myers Beach, FL 33931  
Phone : (239) 765-0202

Posted 11/14/25  
MT

\*\*\*REISSUED\*\*\*

Case Number: 20240733

Date: November 14, 2025

Owner: Midwest Decoration Co  
Mailing Address: 15214 Tonkel Road, Leo, IN 46765  
Property Address: 146 Hercules Dr, Fort Myers Beach, FL 33931  
Certified Mail# 9589071052703142133961 & 9589071052703142172502  
Parcel: 29-46-24-W2-0060A.0110

YOU ARE HEREBY NOTIFIED that the undersigned Code Officer alleges that on October 15, 2025 the following violation(s) of the Florida Building Code, Eighth Edition and the Land Development Code of the Town of Fort Myers Beach, Florida, existed on the property above:

**Code Violation:** On 10/15/2025, a violation was discovered interior and Exterior remodel, exceed the scope of the approved permit 234613. Permit 234613 has expired thus leaving the construction work conducted without the required building permits as defined in Division 3 Section 6-111 (adoption, amendments) of the FMB Code of Ordinances in adoption of the Florida Building Code.

**Relevant Codes:**

**Sec. 6-111. - Adoption; amendments.**

The Florida Building Code is hereby adopted by reference and made a part of this article, including all revisions and amendments approved in accordance with state law, with the exceptions set forth as follows:

**2023 Florida Building Code, Building, Eighth Edition**

**FBC Sec 105.1 Permits required.** Any owner or owner's authorized agent who intends to construct, enlarge, alter, repair, move, demolish or change the occupancy of a building or structure, or to erect, install, enlarge, alter, repair, remove, convert or replace any mechanical, electrical, gas, plumbing or other system, the installation of which is regulated by this code, or to cause any such work to be performed, shall first make application to the building official and obtain the required permit.

**LDG Sec 6-111 - Any owner or owner's authorized agent (hereinafter "applicant") who intends to undertake any development activity within the scope of this article, including buildings, structures and facilities exempt from the Florida Building Code, which is wholly within or partially within any flood hazard area must also obtain to the Executive Administrator the required permits and approvals. No**

Nov 14, 2025 12:12:24 PM  
Fort Myers Beach

requirements of the ordinance and all other applicable codes and regulations has been subject to the requirements of the ordinance and all other applicable codes and regulations that connect two or more existing structures undertake a series of any improvements, additions, and/or demolitions that connect two or more existing structures in a manner that evades the requirements of this ordinance and the Florida Building Code.

CH Pastore  
11-14-25 MJK



# Town of Fort Myers Beach

## NOTICE OF VIOLATION AND NOTICE OF CODE ENFORCEMENT HEARING

6231 Estero Blvd, Fort Myers Beach, FL 33931  
Phone : (239) 765-0202

\*\*\*REISSUED\*\*\*

Date: November 14, 2025

Case Number: 20240733

Owner: **Midwest Decoration Co**  
Mailing Address: 15214 Tonkel Road, Leo, IN 46765  
Property Address: **146 Hercules Dr, Fort Myers Beach, FL 33931**  
Certified Mail# 9589071052703142133961 & 9589071052703142172502  
Parcel: 29-46-24-W2-0060A.0110

YOU ARE HEREBY NOTIFIED that the undersigned Code Officer alleges that on October 15, 2025 the following violation(s) of the Florida Building Code, Eighth Edition and the Land Development Code of the Town of Fort Myers Beach, Florida, existed on the property above:

**Code Violation:** On 10/15/2025, a violation was discovered Interior and Exterior remodel, exceed the scope of the approved permit 234613. Permit 234613 has expired thus leaving the construction work conducted without the required building permits as defined in Division 3 Section 6-111 (adoption; amendments) of the FMB Code of Ordinances in adoption of the Florida Building Code.

**Relevant Codes:**

**Sec. 6-111. - Adoption; amendments.**

The Florida Building Code is hereby adopted by reference and made a part of this article, including all revisions and amendments approved in accordance with state law, with the exceptions set forth as follows:

**2023 Florida Building Code, Building, Eighth Edition**

*FBC Sec 105.1 Permits required. Any owner or owner's authorized agent who intends to construct, enlarge, alter, repair, move, demolish or change the occupancy of a building or structure, or to erect, install, enlarge, alter, repair, remove, convert or replace any impact-resistant coverings, electrical, gas, mechanical or plumbing system, the installation of which is regulated by this code, or to cause any such work to be performed, shall first make application to the building official and obtain the required permit.*

*LDC Sec 6-441 - Any owner or owner's authorized agent (hereinafter "applicant") who intends to undertake any development activity within the scope of this article, including buildings, structures and facilities exempt from the Florida Building Code, which is wholly within or partially within any flood hazard area must first make application to the floodplain administrator, and the building official, if applicable, and must obtain the required permits and approvals. No*

Nov 14, 2025 10:49:31 AM  
Fort Myers Beach





# Property Data

STRAP: 29-46-24-W2-0060A.0110 Folio ID: 10229746

Tax Roll Value Letter 2025

Generated on 12/22/2025 8:15 AM

### Owner Of Record - Sole Owner [\[Change Mailing Address\]](#)



MIDWEST DECORATION CO  
15214 TONKEL RD  
LEO IN 46765

### Site Address

Site Address maintained by [E911 Program Addressing](#)

146 HERCULES DR  
FORT MYERS BEACH FL 33931

### Property Description

Do not use for legal documents!



HERCULES PARK BLK A PB 5 PG 22 LOTS 11 + 12

[View Recorded Plat at LeeClerk.org](#) - Use this link to do an Official Records search on the Lee County Clerk of Courts website, using 5 and 22 for the book and page numbers.

### Attributes and Location Details

Total Bedrooms / Bathrooms	3 / 3.0
Gross Living Area	1,678
1st Year Building on Tax Roll	1958
Historic Designation	No

<b>Township</b>	<b>Range</b>	<b>Section</b>	<b>Block</b>	<b>Lot</b>
46	24E	29	0060A	0110
<b>Municipality</b>	<b>Latitude</b>	<b>Longitude</b>		
Town of Fort Myers Beach	26.4404	-81.92379		

[View Parcel on Google Maps](#)

### [ Tax Map Viewer ] [ View Comparables ]



### [ Pictometry Aerial Viewer ]

### Image of Structure



◀ Photo Date February of 2013 ▶  View other photos

Last Inspection Date: 04/16/2018

## Property Values / Exemptions / TRIM Notices

Generated on 12/22/2025 8:15 AM

No existing exemptions found for this property.

TRIM Notices	Tax Year	Just	Land	Market Assessed	Capped Assessed	Exemptions	Classified Use	Taxable
<a href="#">2025 / Additional Info</a>	2025 (Final Value)	613,611	613,601	613,611	613,611	0	0	613,611
<a href="#">2024 / Additional Info</a>	2024 (Final Value)	773,706	773,696	773,706	773,706	0	0	773,706
<a href="#">2023 / Additional Info</a>	2023 (Corrected Value)	442,811	442,801	442,811	442,811	0	0	442,811

2022 / Additional Info	2022 (Final Value)	752,002	527,900	752,002	199,105	50,000	0	149,105
2021 / Additional Info	2021 (Final Value)	516,619	384,800	516,619	193,306	50,000	0	143,306
2020 / Additional Info	2020 (Final Value)	446,555	384,800	446,555	190,637	50,000	0	140,637
2019 / Additional Info	2019 (Final Value)	435,231	355,800	435,231	186,351	50,000	0	136,351
2018 / Additional Info	2018 (Final Value)	429,598	355,800	429,598	182,876	50,000	0	132,876
2017 / Additional Info	2017 (Final Value)	425,556	338,800	425,556	179,115	50,000	0	129,115
2016	2016 (Final Value)	426,306	338,800	426,306	175,431	50,000	0	125,431
2015	2015 (Final Value)	339,097	338,800	339,097	174,212	50,000	0	124,212
2014	2014 (Final Value)	311,799	220,000	311,799	172,829	50,000	0	122,829
2013	2013 (Final Value)	286,303	155,800	286,303	170,275	50,000	0	120,275
2012	2012 (Final Value)	334,554	230,000	334,554	167,429	50,000	0	117,429
2011	2011 (Final Value)	351,528	230,000	351,528	162,552	50,000	0	112,552
2010	2010 (Final Value)	383,265	260,000	383,265	160,150	50,000	0	110,150
	2009 (Final Value)	430,620	300,000	430,620	155,940	50,000	0	105,940
	2008 (Final Value)	497,140	350,000	497,140	155,780	50,000	0	105,780
	2007 (Final Value)	573,490	425,000	0	151,250	25,000	0	126,250
	2006 (Final Value)	568,110	391,000	0	147,560	25,000	0	122,560
	2005 (Final Value)	439,630	280,500	0	143,260	25,000	0	118,260
	2004 (Final Value)	409,100	300,000	0	139,090	25,000	0	114,090
	2003 (Final Value)	362,710	200,000	0	136,490	25,000	0	111,490
	2002 (Final Value)	212,680	80,000	0	129,890	25,000	0	104,890
	2001 (Final Value)	188,340	80,000	0	127,840	25,000	0	102,840
	2000 (Final Value)	172,290	62,500	0	124,120	25,000	0	99,120
	1999 (Final Value)	165,210	62,500	0	120,860	25,000	0	95,860
	1998 (Final Value)	152,130	62,500	0	118,960	25,000	0	93,960
	1997 (Final Value)	150,190	60,000	0	116,970	25,000	0	91,970
	1996 (Final Value)	146,020	60,000	0	113,560	25,000	0	88,560
	1995 (Final Value)	95,130	55,000	0	95,130	25,000	0	70,130
	1994 (Final Value)	96,750	55,000	0	96,750	0	0	96,750
	1993 (Final Value)	81,850	35,000	0	81,850	0	0	81,850
	1992 (Final Value)	72,940	35,000	0	72,940	0	0	72,940

The **Just** value is the total parcel assessment (less any considerations for the cost of sale). This is the closest value to *Fair Market Value* we produce and is dated as of January 1st of the tax year in question (F.A.C. 12D-1.002).

The **Land** value is the portion of the total parcel assessment attributed to the land.

The **Market Assessed** value is the total parcel assessment (less any considerations for the cost of sale) based upon the assessment standard. Most parcels are assessed based either upon the *Highest and Best Use* standard or the *Present Use* standard (F.S. 193.011). For *Agriculturally Classified* parcels (or parts thereof), only agricultural uses are considered in the assessment (F.S. 193.461 (6) (a)). The difference between the *Highest and Best Use/Present Use* and the *Agricultural Use* is often referred to as the *Agricultural Exemption*.  
(i.e. Market Assessed = Just - Agricultural Exemption)

The **Capped Assessed** value is the *Market Assessment* after any *Save Our Homes* or *10% Assessment Limitation* cap is applied. This assessment cap is applied to all properties and limits year-to-year assessment increases to either the *Consumer Price Index* or 3%, whichever is lower for *Homestead* properties OR 10% for non-*Homestead* properties.

The **Exemptions** value is the total amount of all exemptions on the parcel.

The **Taxable** value is the *Capped Assessment* after exemptions (*Homestead, etc.*) are applied to it. This is the value that most taxing authorities use to calculate a parcel's taxes.  
(i.e. Taxable = Capped Assessed - Exemptions)

## Property Details (Current as of 12/21/2025)

Generated on 12/22/2025 8:15 AM

### Land

#### Land Tracts

Use Code	Use Code Description	Number of Units	Unit of Measure
100	Single Family Residential	2.00	Units

#### Buildings

**Building 1 of 1**

**Building Characteristics**

<b>Improvement Type</b>	<b>Model Type</b>	<b>Stories</b>	<b>Living Units</b>
103 - Split Entry/Raised Ranch	1 - SINGLE FAMILY RESIDENTIAL	1.0	1
<b>Bedrooms</b>	<b>Bathrooms</b>	<b>Year Built</b>	<b>Effective Year Built</b>
3	3.0	1958	1992

**Building Subareas**

<b>Description</b>	<b>Heated / Under Air</b>	<b>Area (Sq Ft)</b>
BAS - BASE	Y	1,484
BAS - BASE	Y	194
FLU - FINISHED LOWER UTILITY	N	623
FOP - FINISHED OPEN PORCH	N	35
FOP - FINISHED OPEN PORCH	N	193
LCP - LOWER CARPORT / OPEN PORCH	N	1,430
STP - STOOP	N	252
STP - STOOP	N	65

**Building Front Photo**



**Photo Date: February of 2013**

**Building Footprint**

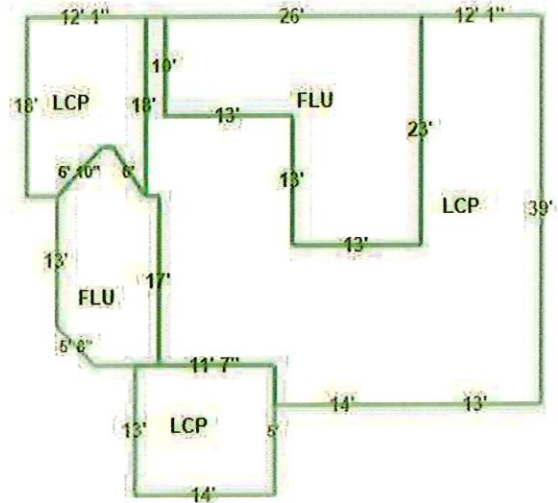

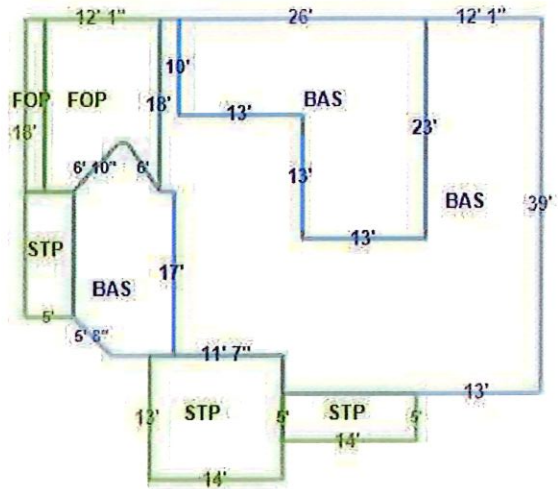

## Property Details (2025 Tax Roll)

Generated on 12/22/2025 8:15 AM

### Land

#### Land Tracts

Use Code	Use Code Description	Number of Units	Unit of Measure
100	Single Family Residential	2.00	Units

### Buildings

#### Building 1 of 1

#### Building Characteristics

Improvement Type	Model Type	Stories	Living Units
103 - Split Entry/Raised Ranch	1 - SINGLE FAMILY RESIDENTIAL	1.0	1
Bedrooms	Bathrooms	Year Built	Effective Year Built
3	3.0	1958	1992

#### Building Subareas

Description	Heated / Under Air	Area (Sq Ft)
BAS - BASE	Y	1,484
BAS - BASE	Y	194
FLU - FINISHED LOWER UTILITY	N	623
FOP - FINISHED OPEN PORCH	N	35
FOP - FINISHED OPEN PORCH	N	193
LCP - LOWER CARPORT / OPEN PORCH	N	1,430
STP - STOOP	N	252
STP - STOOP	N	65

Building Front Photo

Building Footprint



Photo Date: February of 2013

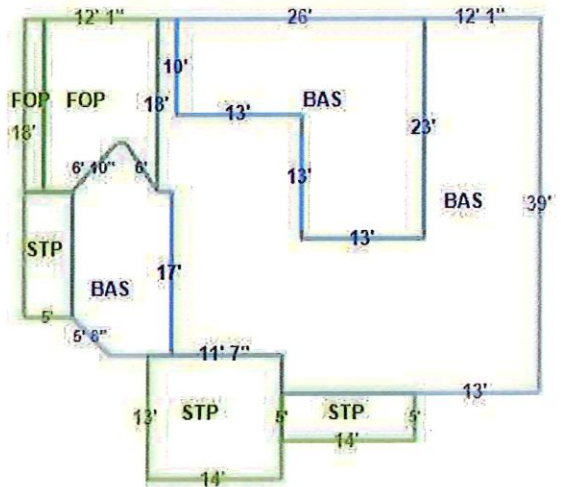
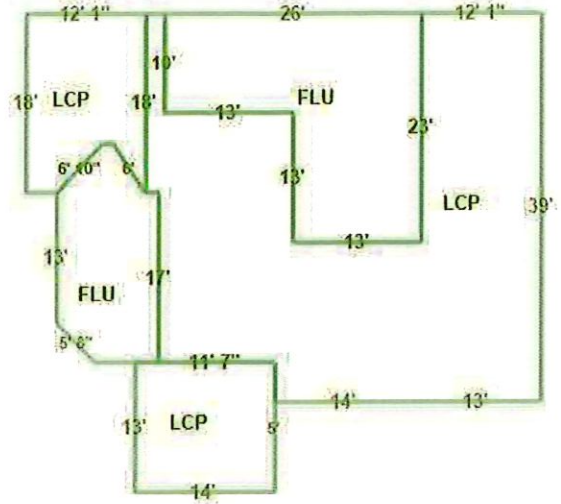

## Taxing Authorities

Generated on 12/22/2025 8:15 AM

TOWN OF FT MYERS BEACH / 032

Name / Code	Category	Mailing Address
LEE CO GENERAL REVENUE / 044	County	LEE COUNTY OFFICE OF MGMT & BUDGET PO BOX 398 FORT MYERS FL 33902-0398
FORT MYERS BEACH FIRE CONTROL DIST / 032	Independent District	FORT MYERS BEACH FIRE CONTROL DIST 100 VOORHIS ST FORT MYERS BEACH FL 33931
FORT MYERS BEACH MOSQUITO CONTROL / 035	Independent District	FORT MYERS BEACH MOSQUITO CONTROL PO BOX 2837 FORT MYERS BEACH FL 33932-2837
FORT MYERS BEACH PUBLIC LIBRARY DIST / 033	Independent District	FORT MYERS BEACH PUBLIC LIBRARY DIST 2755 ESTERO BLVD FORT MYERS BEACH FL 33931

LEE CO HYACINTH CONTROL DIST / 051	Independent District	LEE CO HYACINTH CONTROL DIST 15191 HOMESTEAD RD LEHIGH ACRES FL 33971
WEST COAST INLAND NAVIGATION DIST / 098	Independent District	WEST COAST INLAND NAVIGATION DIST 200 MIAMI AVE E VENICE FL 34285-2408
TOWN OF FORT MYERS BEACH FLORIDA / 118	Municipal	TOWN OF FORT MYERS BEACH 2523 ESTERO BLVD FORT MYERS BEACH FL 33931
PUBLIC SCHOOL - BY LOCAL BOARD / 012	Public Schools	LEE COUNTY SCHOOL BOARD BUDGET DEPARTMENT 2855 COLONIAL BLVD FORT MYERS FL 33966
PUBLIC SCHOOL - BY STATE LAW / 013	Public Schools	LEE COUNTY SCHOOL BOARD BUDGET DEPARTMENT 2855 COLONIAL BLVD FORT MYERS FL 33966
GREEN CORRIDOR PACE / 363	Special District	
SFWMD-DISTRICT-WIDE / 110	Water District	SFWMD 3301 GUN CLUB RD WEST PALM BEACH FL 33406
SFWMD-EVERGLADES CONSTRUCTION PROJECT / 084	Water District	SFWMD 3301 GUN CLUB RD WEST PALM BEACH FL 33406
SFWMD-OKEECHOBEE BASIN / 308	Water District	SFWMD 3301 GUN CLUB RD WEST PALM BEACH FL 33406

## Sales / Transactions

Generated on 12/22/2025 8:15 AM

Sale Price	Date	Clerk File Number	Type	Notes	Vacant/ Improved
700,000.00	04/14/2023	2023000167724	01		I
100.00	11/09/2004	4516/299	01		I
71,500.00	09/01/1987	1944/1293	03		I
0.00	01/01/1980	1404/421	01		I

[View Recorded Plat at LeeClerk.org](#)

Use the above link to do a search on the Lee County Clerk of Courts website, using 5 and 22 for the book and page numbers and **Plats Book** for the book type.

Help safeguard your home against property fraud. Sign up for the Lee Clerk's free [Property Fraud Alert](#).

## Building / Construction Permit Data

Generated on 12/22/2025 8:15 AM

Permit Number	Permit Type	Date
235522	Building Remodel / Repair	09/22/2023
234613	Building Remodel / Repair	07/12/2023
ROF14-0028	Roof	04/21/2014
BLD12-0095	Building Remodel / Repair	06/26/2012

**IMPORTANT: THIS MAY NOT BE A COMPREHENSIVE OR TIMELY LISTING OF PERMITS ISSUED FOR THIS PROPERTY.**

Note: The Lee County Property Appraiser's Office does not issue or maintain any permit information. The Building / Construction permit data displayed here represents only those records this Office may find necessary to conduct Property Appraiser business. Use of this information is with the understanding that in no way is this to be considered a comprehensive listing of permits for this or any other parcel.

The Date field represents the date the property appraiser received information regarding permit activity; it may or not represent the actual date of permit issuance or completion.

Full, accurate, active and valid permit information for parcels can only be obtained from the [appropriate permit issuing agency](#).

### Parcel Numbering History ⓘ

Generated on 12/22/2025 8:15 AM

Prior STRAP	Prior Folio ID	Renumber Reason	Renumber Date
29-46-24-06-0000A.0110	N/A	Reserved for Renumber ONLY	01/12/1995

### Solid Waste (Garbage) Roll Data

Generated on 12/22/2025 8:15 AM

Solid Waste District	Roll Type	Category	Unit / Area	Tax Amount
001 - Service Area 1	R - Residential Category		1	358.45
	<b>Collection Days</b>			
<b>Garbage</b>	<b>Recycling</b>	<b>Horticulture</b>		
Thursday	Thursday	Thursday		

### Flood and Storm Information

Generated on 12/22/2025 8:15 AM

[Flood Insurance](#) [Find my flood zone](#)

Community	Panel	Version	Date	Evacuation Zone
071C	0558	G	11/17/2022	A

Generated on 12/22/2025 8:15 AM

**DO NOT PAY - THIS IS NOT A BILL**  
**NOTICE OF PROPOSED PROPERTY TAXES**  
**TAX INFORMATION**

10229746  
 MIDWEST DECORATION CO  
 15214 TONKEL RD  
 LEO, IN 46765

071060  
 Parcel ID: 29-46-24-W2-0060A.0110  
 HERCULES PARK  
 BLK A PB 5 PG 22  
 LOTS 11 + 12  
 146 HERCULES DR

The taxing authorities which levy property taxes against your property will soon hold PUBLIC HEARINGS to adopt budgets and tax rates for the next year.

The purpose of these PUBLIC HEARINGS is to receive opinions from the general public and to answer questions on the proposed tax change and budget PRIOR TO TAKING FINAL ACTION. Each taxing authority may AMEND OR ALTER its proposals at the hearing.

TAXING AUTHORITY		COLUMN 1*		COLUMN 2*		COLUMN 3*
032 TOWN OF FT MYERS BEACH	LAST YEAR'S ACTUAL TAX RATE 2024 (MILLAGE)	YOUR PROPERTY TAXES LAST YEAR 2024	YOUR TAX RATE THIS YEAR IF NO BUDGET CHANGE IS ADOPTED (MILLAGE)	YOUR TAXES THIS YEAR IF NO BUDGET CHANGE IS ADOPTED	THIS YEAR'S PROPOSED TAX RATE 2025 (MILLAGE)	YOUR TAXES IF PROPOSED BUDGET CHANGE IS ADOPTED 2025
<b>COUNTY:</b>						
LEE CO GENERAL REVENUE	3.7623	\$2,910.91	3.6162	\$2,218.94	3.7623	\$2,308.59
<b>SCHOOL:</b>						
PUBLIC SCHOOL - BY LOCAL BOARD	2.2480	\$1,739.29	2.2302	\$1,368.48	2.2480	\$1,379.40
PUBLIC SCHOOL - BY STATE LAW	3.0380	\$2,350.52	3.0139	\$1,849.36	3.0710	\$1,884.40
<b>MUNICIPALITY OR MSTU:</b>						
TOWN OF FORT MYERS BEACH FLORIDA	0.9900	\$765.97	0.8954	\$549.43	1.2550	\$770.08
<b>WATER MANAGEMENT DISTRICT:</b>						
SFWM-DISTRICT-WIDE	0.0948	\$73.35	0.0889	\$54.55	0.0948	\$58.17
SFWM-EVERGLADES CONSTRUCTION PROJECT	0.0327	\$25.30	0.0306	\$18.78	0.0327	\$20.07
SFWM-OKEECHOBEE BASIN	0.1026	\$79.38	0.0961	\$58.97	0.1026	\$62.96
<b>INDEPENDENT SPECIAL DISTRICTS:</b>						
FORT MYERS BEACH FIRE CONTROL DIST	2.8000	\$2,166.38	2.5436	\$1,560.78	2.8000	\$1,718.11
FORT MYERS BEACH MOSQUITO CONTROL	0.1123	\$86.89	0.1018	\$62.47	0.1123	\$68.91
FORT MYERS BEACH PUBLIC LIBRARY DIST	0.1612	\$124.72	0.1464	\$89.83	0.1612	\$98.91
LEE CO HYACINTH CONTROL DIST	0.0200	\$15.47	0.0192	\$11.78	0.0200	\$12.27
WEST COAST INLAND NAVIGATION DIST	0.0394	\$30.48	0.0381	\$23.38	0.0394	\$24.18
<b>TOTAL TAX RATES:</b>	13.4013		12.8204		13.6993	
<b>TOTAL PROPERTY TAXES:</b>		\$10,368.66		\$7,866.75		\$8,406.05
		<b>COLUMN 1*</b>		<b>COLUMN 2*</b>		<b>COLUMN 3*</b>

**NOTICE OF PROPOSED PROPERTY TAXES EXPLANATION (Section 200.069, Florida Statutes)**

**\*COLUMN 1**—"YOUR PROPERTY TAXES LAST YEAR" - This column shows the taxes that applied last year to your property. These amounts were based on budgets adopted last year and your property's previous taxable value.

**\*COLUMN 2**—"YOUR TAXES IF NO BUDGET CHANGE IS ADOPTED" - This column shows what your taxes will be this year IF EACH TAXING AUTHORITY DOES NOT CHANGE ITS PROPERTY TAX LEVY. These amounts are based on last year's budgets and your current assessment.

**\*COLUMN 3**—"YOUR TAXES IF PROPOSED BUDGET CHANGE IS ADOPTED" - This column shows what your taxes will be this year under the BUDGET ACTUALLY PROPOSED by each local taxing authority. The proposal is NOT final and may be amended at the public hearings shown on this notice. The difference between Columns 2 and 3 is the tax change proposed by each local taxing authority and is NOT the result of higher assessments.

**NOTE:** Amounts shown on this form do NOT reflect early payment discounts you may have received or may be eligible to receive. (Discounts are a maximum of 4 percent of the amounts shown on this form.)

**NON-AD VALOREM ASSESSMENTS:** Your final tax bill may contain non-ad valorem assessments which may not be reflected on this notice such as assessments for roads, fire, garbage, lighting, drainage, water, sewer, or other governmental services and facilities which may be levied by your county, city, or any special district

**A Public Hearing on the Proposed Taxes and Budget Will Be Held:**

COUNTY/MSTU:	09/04/2025 5:05PM	Lee Co Commission Chambers	2120 Main St	Fort Myers FL 33901	239-533-2221
SCHOOL:	09/09/2025 5:05PM		2855 Colonial Blvd	Fort Myers FL 33966	239-337-8215
MUNICIPALITY:	09/11/2025 5:01PM		6231 Estero Blvd	Fort Myers Beach FL 33931	239-765-0202
WATER MANAGEMENT DISTRICT:	09/11/2025 5:15PM	SFWM Auditorium	3301 Gun Club Rd B-1 Bldg	West Palm Beach FL 33406	561-686-8800
LEE CO MOSQUITO AND/OR HYACINTH:	09/11/2025 5:01PM/5:15PM		15191 Homestead Rd	Lehigh Acres FL 33971	239-694-2174
FORT MYERS BEACH FIRE CONTROL DIST:	09/10/2025 5:05PM	Diamond Head Resort	2000 Estero Blvd	Ft Myers Beach FL 33931	239-590-4200
FORT MYERS BEACH MOSQUITO CONTROL:	09/03/2025 5:01PM		161 Bay Rd	Ft Myers Beach FL 33931	239-247-1205
FORT MYERS BEACH PUBLIC LIBRARY DIST:	09/11/2025 5:05PM		2755 Estero Blvd	Ft Myers Beach FL 33931	239-463-9691
WEST COAST INLAND NAVIGATION DISTRICT:	09/05/2025 5:01PM		1575 E Venice Ave	Venice FL 34292	941-485-9402

\*\* PROPERTY RECORD UPDATE -- WEBSITE AND PERSONALIZED CODE FOR 2025\*\*

Enter your [personalized code TR9C17F2](#) to review your property details and

- Report or update hurricane damage

- Confirm or update your homestead exemption status
- Discover how your value was impacted

PROPERTY VALUATION		
	Last Year 2024 ⓘ	This Year 2025 ⓘ
<b>MARKET VALUE</b>	<b>\$773,706</b>	<b>\$613,611</b>
<p><b>Market Value</b> in Florida is also known as "just value" as provided by the constitution and described in state law. It is the amount a purchaser willing but not obliged to buy would pay to one willing but not obliged to sell, after proper consideration of all eight factors in section 193.011, F.S.</p>		
<b>ASSESSED VALUE</b>		
<p><b>Assessed Value</b> is the market value of your property minus the amount of any assessment reductions. The assessed value may be different for millage levies made by different taxing authorities.</p>		
ASSESSMENT REDUCTIONS	APPLIES TO	VALUE
<p><b>Assessment Reduction</b> amounts are based on applicable statutory limitations and benefits that may affect the Assessed Value, such as the Save Our Homes cap or an Agricultural Classification. The value of these limitations and benefits make up the difference between market and assessed value.</p>		

EXEMPTIONS	APPLIES TO	VALUE
<p><b>Exemptions</b> are specific dollar or percentage amounts that reduce taxable value. These are usually based on characteristics of the property or property owner. Examples include the homestead exemption, veterans' disability exemptions and charitable exemptions. In some cases, the maximum exemption amount may not be applied because of a lower assessed value. Many exemptions apply only to tax levies by the taxing authority granting the exemption.</p>		

VALUE CALCULATIONS						
<p><b>Taxable Value</b> is the assessed value minus qualifying exemptions. This is the value used to calculate the tax due on your property. The assessed and taxable values may vary by taxing authority because certain assessment reductions and exemptions may not apply to all levies and discounts.</p>						
TAXING AUTHORITY	ASSESSED VALUE		EXEMPTIONS		TAXABLE VALUE	
	LAST YEAR	THIS YEAR	LAST YEAR	THIS YEAR	LAST YEAR	THIS YEAR ⓘ
<b>COUNTY:</b>						
LEE CO GENERAL REVENUE	\$773,706	\$613,611	\$0	\$0	\$773,706	\$613,611
<b>SCHOOL:</b>						
PUBLIC SCHOOL - BY LOCAL BOARD	\$773,706	\$613,611	\$0	\$0	\$773,706	\$613,611
PUBLIC SCHOOL - BY STATE LAW	\$773,706	\$613,611	\$0	\$0	\$773,706	\$613,611
<b>MUNICIPALITY OR MSTU:</b>						
TOWN OF FORT MYERS BEACH FLORIDA	\$773,706	\$613,611	\$0	\$0	\$773,706	\$613,611
<b>WATER MANAGEMENT DISTRICT:</b>						
SFWMD-DISTRICT-WIDE	\$773,706	\$613,611	\$0	\$0	\$773,706	\$613,611
SFWMD-EVERGLADES CONSTRUCTION PROJECT	\$773,706	\$613,611	\$0	\$0	\$773,706	\$613,611
SFWMD-OKEECHOBEE BASIN	\$773,706	\$613,611	\$0	\$0	\$773,706	\$613,611
<b>INDEPENDENT SPECIAL DISTRICTS:</b>						
FORT MYERS BEACH FIRE CONTROL DIST	\$773,706	\$613,611	\$0	\$0	\$773,706	\$613,611
FORT MYERS BEACH MOSQUITO CONTROL	\$773,706	\$613,611	\$0	\$0	\$773,706	\$613,611
FORT MYERS BEACH PUBLIC LIBRARY DIST	\$773,706	\$613,611	\$0	\$0	\$773,706	\$613,611
LEE CO HYACINTH CONTROL DIST	\$773,706	\$613,611	\$0	\$0	\$773,706	\$613,611
WEST COAST INLAND NAVIGATION DIST	\$773,706	\$613,611	\$0	\$0	\$773,706	\$613,611

If you feel the market value of your property is inaccurate or does not reflect fair market value, or if you are entitled to an exemption or classification that is not reflected on this form, please call us at (239) 533-6100 or visit the Lee County Property Appraiser's office at 2480 Thompson Street, 4th Floor, Fort Myers, FL.

If we are unable to resolve a matter as to the market value, classification, or an exemption, you may file a petition for adjustment with the Value Adjustment Board. ⓘ Online filing is available at [www.leeclerk.org](http://www.leeclerk.org). Petition forms are available from the Lee County Property Appraiser's office. All petitions must be filed with the Clerk of Courts Office on or before September 12, 2025.

\*\* PROPERTY RECORD UPDATE -- WEBSITE AND PERSONALIZED CODE FOR 2025\*\*

Enter your [personalized code TR9C17F2](#) to review your property details and

- Report or update hurricane damage
- Confirm or update your homestead exemption status
- Discover how your value was impacted



[Department of State](#) / [Division of Corporations](#) / [Search Records](#) / [Search By Entity Name](#) /

[Next List](#)

MIDWEST DECORATION C

### Entity Name List

Corporate Name	Document Number	Status
<a href="#">THE MIDWEST DEFENDERS OF ISRAEL, INC</a>	N19000012992	INACT
<a href="#">MIDWEST DENTAL ARTS, INC.</a>	F13000005030	Active
<a href="#">MIDWEST DESIGN GROUP LLC</a>	M22000014835	Active
<a href="#">MIDWEST DETASSELING, LLC</a>	L12000132437	INACT
<a href="#">MIDWEST DETOX AT AMBROSIA LLC</a>	L23000294420	Active
<a href="#">MIDWEST DEVELOPERS, LLC</a>	L06000023861	Active
<a href="#">MIDWEST DEVELOPMENT, INC.</a>	H75334	INACT
<a href="#">MIDWEST DEVELOPMENT CORP</a>	P04000129714	INACT
<a href="#">MID-WEST DEVELOPMENT CORPORATION OF FORT LAUDERDALE</a>	227189	INACT
<a href="#">MIDWEST DIAGNOSTIC MANAGEMENT, LLC</a>	M07000005692	INACT
<a href="#">MIDWEST DIAL TONE, LLC</a>	M21000009534	Active
<a href="#">MIDWEST DIESEL CONSULTANTS LLC</a>	L21000388766	INACT
<a href="#">MIDWEST DIGITAL SOLUTIONS LLC</a>	L18000167552	INACT
<a href="#">MIDWEST DIRECT INC</a>	P04000096673	INACT
<a href="#">MID-WEST DIRECT INC.</a>	P94000050117	INACT
<a href="#">MIDWEST DISCOUNT BROKERS, INC.</a>	F98000005791	INACT
<a href="#">MIDWEST DISPOSAL, INC.</a>	P95000014637	INACT
<a href="#">MIDWEST DISTRIBUTING COMPANY INC</a>	174354	INACT
<a href="#">MIDWEST DISTRIBUTING SERVICE, INC.</a>	490033	INACT
<a href="#">MID WEST DISTRIBUTORS, INC.</a>	L53137	INACT

[Next List](#)

MIDWEST DECORATION C

**BUSINESS INFORMATION**  
DIEGO MORALES  
INDIANA SECRETARY OF STATE  
12/22/2025 08:19 AM

**Business Details**

Business Name: **MIDWEST DECORATION CO.** Business ID: **201812061292509**  
Entity Type: **Domestic For-Profit Corporation** Business Status: **Active**  
Creation Date: **12/06/2018** Inactive Date:  
Principal Office Address: **15214 Tonkel Road, Leo, IN, 46765, USA** Expiration Date: **Perpetual**  
Jurisdiction of Formation: **Indiana** Business Entity Report Due Date: **12/31/2026**  
Years Due:

**Governing Person Information**

Title	Name	Address
President	Casey S Johnson	1332 Brandon Way, Fort Wayne, IN, 46845, USA
President	Casey Johnson	1332 Brandon Way, Fort Wayne, IN, 46845, USA
President	Casey Johnson	1332 Brandon Way, Fort Wayne, IN, 46845, USA

**Incorporators Information**

Name	Title	Address
Charles J Heiny	Incorporator	444 East Main Street, Fort Wayne, IN, 46802, USA

**Registered Agent Information**

Type: **Individual**  
Name: **Casey S. Johnson**  
Address: **1332 Brandon Way, Fort Wayne, IN, 46845, USA**

Case #: 20250804 Contractor Name: [ ] Time of Site Inspection: [ ] Case Closed: [ ]

Case Date: 08/01/25 Compliance Date of Violation: [ ] Citation Number: [ ] Repair Damage Due To: [ ]

Case Type: Work without Permit Hearing Date: 12/04/2025 How to bring violation into compliance: [ ] Storm Damage: [ ]

Description: Paperwork Completion Date of Site Inspection: [ ] Days to Comply: [ ] Assigned To: Michael Hauserman

Status: -- Referred: -- GIS Link ID: 294624W20060A0110

Cases For Property (Code Enforcement)

Permits For Property (Permit Management)

Date	Permit #	Permit Type	Status	Permit Type	Sub Type	Assigned To	Type of Construction	Type of Occupancy/Use	Contractor Business Name/Applicant
11/20/2025	252335		FINALED	Residential	OTC Electrical	N/A		Residential	Miser Sparty
02/14/2025	250379		FINALED	Residential	Fence	N/A		Residential	Russ Carter Fence
12/10/2024	243194		FINALED	Residential	Pool-Below Ground	N/A		Residential	Rum Row Pools
09/07/2023	235522		FINALED	Residential	OTC Mechanical	N/A		Residential	COOL AIR PROS
08/14/2023	235122		VOID	Residential	OTC Electrical				
07/05/2023	234613		HOLD	Residential	Remodel	N/A		Residential	EVERGLADES CONSTRUCTION GROUP
10/22/2018	181937		FINALED	ZOTC Mechanical	Not Required				UNIQUE SERVICES

Show Last 25 | Show All

Show Last 25 | Show All



**Permit #:** 234613

**Permit Date:** 07/05/23

**Permit Type:**

**Permit Type:** Residential

**Sub Type:** Remodel

**Type of Construction:** N/A

**Type of Occupancy / Use:** Residential

**Contractor Business Name/Applicant:** EVERGLADES CONSTRUCTION GROUP

**Contact Name:** BRITTNEY SABULA

**Contractor/Applicant Email:** brittney@evergladesconstructiongroup.com

**Contractor/Applicant Phone #:** 8632543028

**Property Owner's Email:**

**Current Use:** r

**Proposed Use:** r

**Scope of Work:** Interior put back after Hurricane Ian. Like for like.

**Project Cost:** 82273

**Gross Square Feet:** 1678

**Issued Date:** 07/12/2023

**Expiration Date:** 01/24/2024

**Final Date:**

**Closed Date:**

**Repair Damage Due To:**

**Storm Damage:**

**Floodplain:**

**Status:** HOLD

**Assigned To:**

### Property

Parcel #	Address	Legal Description	Owner Name	Owner Phone	Zoning
294624W20060A0110	146 HERCULES DR	HERCULES PARK BLK A PB 5 PG 22 LOTS 11 + 12	MIDWEST DECORATION CO		RS-1

### Contractors

Contractor	Primary Contact	Phone	Address	Contractor Type	License	License #
Everglades Construction Group LLC	David Ryan Edmonds	863-254-3028	214 E. Crescent Drive	Certified General	Liability Insurance	NPP1549804
West Coast Plumbing & Water Treatment, LLC	Brian Wallin	239-340-8224	5651 Halifax Ave	Certified Plumbing	Comm. Gen. Liability	20362149

West Coast Plumbing & Water Treatment, LLC	Brian Wallin	239-340-8224	5651 Halifax Ave	Certified Plumbing	Work Comp	EIG588433000
Everglades Construction Group LLC	David Ryan Edmonds	863-254-3028	214 E. Crescent Drive	Certified General	Contractor License	CGC1522985
West Coast Plumbing & Water Treatment, LLC	Brian Wallin	239-340-8224	5651 Halifax Ave	Certified Plumbing	State of Florida	CFC1427865
Everglades Construction Group LLC	David Ryan Edmonds	863-254-3028	214 E. Crescent Drive	Certified General	Workman's Comp	WC Exempt

## Inspections

Date	Inspection Type	Description	Scheduled Date	Completed Date	Inspector	Status
02/06/2024	Electrical - 305 Electric Final	aLL KITCH AND DW AND GD IS MISSING GFI PROTECTION AND ALL NEW RECEP TO COMPLY WITH SECTION 406.4(D)	02/08/2024	02/08/2024	Ron Cohowcz	Fail
02/06/2024	Plumbing - 204 Final Plumbing	Call Melissa when you arrive 757-692-4600 Call Melissa when you arrive 757-692-4600 plumbing fixtures hook up only	02/08/2024	02/08/2024	Ron Cohowcz	Pass
11/07/2023	Building - 106 Final Building	Pending EL & PL Finals. A.S.	11/13/2023	11/14/2023	Adam Stauffer	Pass with Conditions
07/28/2023	Building - 105 Rough Framing / Windows, Door, Wall Dry In	picked this inspection up no visible framing members changes just some 3/4 " flooring replaced jmc 7/28/23	07/28/2023	07/28/2023	John Clements	Pass
07/27/2023	Building - 107 Insulation	scope shows no rough inspections only finals insulation on 2nd fl ok walls only 1st floor floor joists spray foam insulation but stated in scope no work on 1st floor jmc 7/28/23	07/28/2023	07/27/2023	John Clements	Pass with Conditions
07/06/2023	NOC		07/06/2023	07/06/2023	Misty Alexander	Pass

## Plan Reviews

Date	Review Type	Description	Assigned To	Review Status
07/05/2023	Notice of Commencement	NOC must be recorded with Lee County Clerk of Court *Received 7/6/23	Misty Alexander	DONE
07/05/2023	Reviews completed- Notification sent		Andrew Garry	DONE
07/05/2023	Review Flood		CGA	REVIEWED W/CONDITIONS
07/06/2023	Review Res. Plan review		CGA	REVIEWED FOR COMPLIANCE
07/05/2023	Review FMB Application	Check INBiz for Casey Johnson.	Tracie Raski	DONE
11/07/2023	Plumb. Sub Permit Req	West Coast Plumbing & Water Treatment LLC CFC1427865	Misty Alexander	DONE
02/28/2024	Elec. Sub Permit Req.		*	
05/20/2024	Review Flood		Rereview Kristin Schumacher	RESUBMITTAL REQUIRED
05/20/2024	Rejection Letter Sent	1st Flood review rejection letter has been uploaded to the permit portal for review.	Korey Lastinger	DONE

08/23/2024	Resubmitted (Flood Review)	RE-REVIEW RESUB FLOOD	Carl Thomas	REVIEWED W/CONDITIONS
09/11/2024	Review Flood	Re-Review	Carl Thomas	RESUBMITTAL REQUIRED
09/19/2024	Rejection Letter Sent	2nd flood rejection	Misty Alexander	DONE

## Fees

Fee	Description	Notes	Amount
RES – Interior Remodel (up to 50% of Structure Value) (2024)	Includes: Application Processing Fee Building Review and Inspection Flood Review Electrical Review and Inspection Mechanical Review and Inspection Plumbing Review and Inspection		\$800.00
* MISC- DBPR & DCA Admin Fees			\$20.00
		<b>Total</b>	<b>\$820.00</b>

## Attached Letters

Date	Letter	Description
07/12/2023		<a href="#">Building Permit</a>

## Payments

Date	Paid By	Description	Payment Type	Accepted By	Amount
07/06/2023	NICHOLAS SABULA	Invoice: 644574			\$820.00
				<b>Outstanding Balance</b>	<b>\$0.00</b>

## Notes

Date	Note	Created By:
08/15/2024	Received a voicemail from Nick #713-443-7963 requesting a call back. I called with negative results and leaving a voicemail requesting a call back. Received call from Nick and advised of what needs to be corrected and collected regarding permit #234613. He advised he would contact permitting and get corrected immediately.	D. Batt
08/01/2024	Called and spoke with property owner Casey #260-417-6667. I advised him of the permit being on hold and that he needs to contact permitting in which he agreed to call the contractor and have it rectified.	D. Batt
06/06/2024	Permit has been placed on HOLD until they have come into compliance.	Tracie Raski
05/17/2024	Need new cost form and proper breakdown of all costs. Need break down for labor, materials-cabinets, countertops, plumbing fixtures, all electrical repairs, doors, windows and any additional repairs done.	Kristin Schumacher
02/28/2024	You must attach an electrical sub-contractor to this permit.	Andrew Garry

## Uploaded Files

Date	File Name
10/31/2025	<a href="#">29243264-146 Hercules .xlsx</a>
09/19/2024	<a href="#">22453708-234613 2nd Flood Rejection Letter.pdf</a>
08/23/2024	<a href="#">22126635-20736621-1st Flood Review Rejection Letter 234613.pdf</a>
08/23/2024	<a href="#">22126634-234613 Updated Cost Sheet.pdf</a>
05/20/2024	<a href="#">20736621-1st Flood Review Rejection Letter 234613.pdf</a>
11/07/2023	<a href="#">17421760-234613 07-Nov-2023 09-47-48.pdf</a>
08/10/2023	<a href="#">16465647-234613.pdf</a>
07/11/2023	<a href="#">16100459-JOBSITE COPY 234613.pdf</a>
07/06/2023	<a href="#">16052353-Notice Of Commencement (8).pdf</a>

07/06/2023

07/03/2023

07/03/2023

[16050384-warranty deed 234613 05-Jul-2023 14-43-46.pdf](#)

[9e21126892498d7a85358c56ac72b0a9\\_146\\_hercules\\_tax\\_roll\\_letter.pdf](#)

[01f7a21870bcff9bb07f7828768d767\\_146\\_hercules\\_permit\\_app\\_packet.pdf](#)



Date: 09/19/2024  
Contractor: Everglades Construction Group  
RE: 234613

The drawings submitted for the referenced project have been reviewed following the 8<sup>th</sup> Edition (2023) Florida Building Codes, Florida Statutes (F.S), and the Town of Fort Myers Beach Land Development Code. For the reasons listed below, we cannot approve your application at this time.

---

*Please provide the Rejection Letter and a Cover Letter showing where each corrected item can be found.*

2nd Rejection Letter – Flood  
Carl Thomas, [cthomas@fmbgov.com](mailto:cthomas@fmbgov.com) (Flood Reviewer)

**REJECTION COMMENTS:**

Based on the information below, the structure appears to meet substantial damage and must be redesigned to meet current flood design criteria (i.e., elevate, floodproof) based on the following:

-The current cost of repairs is already 40% of the structural value and includes no line items for carpentry, roofing, windows, exterior finish, etc. Adding these additional repairs will increase the costs by over 50%.

-Insurance claim payout information: FEMA makes it abundantly clear that insurance claims cannot be used as the basis for determining substantial damage. This is because insurance claims usually only cover some associated costs to restore the structure to its pre-lan conditions. In this case, the claim, even though it may not cover all repairs, is already over the 50% structural value.

**PLEASE NOTE:**

- Mailed in or paper plans will not be accepted.
- Submit all corrections together at one time with an appropriate response/ cover letter showing where each corrected item can be found to [resubmittal@fmbgov.com](mailto:resubmittal@fmbgov.com).
- Please note that no other reviews will be done until the **Zoning Review** is approved.
- Resubmittals will not be processed unless all review comments are addressed.

Please refer to the **Permit Portal** to access a copy of this rejection letter.

Sincerely,

Town of Fort Myers Beach Building Services and Community Development Departments.



Oct 15, 2025 3:20:34 PM  
Fort Myers Beach



Oct 15, 2025 3:20:24 PM  
Fort Myers Beach



Oct 15, 2025 3:19:59 PM  
Fort Myers Beach



Oct 15, 2025 3:21:08 PM  
Fort Myers Beach

# **EXHIBIT B**

**Notice of Violation and Hearing 12/29/2025**

**Affidavit of Service**

**Proof of Service**



Town of Fort Myers Beach

6231 Estero Blvd, Florida 33931  
Phone: 239-765-0202 Fax: 239-765-0909

TOWN OF FORT MYERS BEACH,  
FLORIDA,

Petitioner,  
vs.

MIDWEST DECORATION CO  
Respondent.

Certified Mail:	9589071052703142134333
	9589071052703142134326
Regular Mail:	USPS 12/30/2025
Case #	20240733

AFFIDAVIT OF NOTICE AND POSTING

STATE OF FLORIDA  
COUNTY OF LEE

BEFORE ME, the undersigned authority, personally appeared Michael J Hauserman, who being duly sworn by me, on oath, deposes and says the following regarding that certain Notice of Violation and Notice of Hearing attached hereto as **Exhibit A** (“the Notice”):

1. My name is Michael J Hauserman. I am over 18 years of age and am competent to testify to the matters set forth herein. I make this Affidavit based upon my personal knowledge.
2. I am employed as the Code Compliance Manager for the Town of Fort Myers Beach (“Town”).
3. On 12/30/2025, I personally mailed a copy of the Notice by certified mail and first-class mail as follows:
  - a. To the property owner at the address listed in the records of the Lee County Tax Collector and/or Lee County Property Appraiser for tax notices, which address is: **15214 Tonkel Rd, Leo, IN 46765**. A true and correct copy of the property ownership and address information obtained from the Tax Collector/Property Appraiser is attached hereto as **Exhibit A**. A copy of the certified mail receipt is attached hereto as **Exhibit A**.

- b. To the following additional address(es) reasonably believed to be valid for the property owner: **146 Hercules Dr, Fort Myers Beach, FL 33931**. A copy of the certified mail receipt is attached hereto as **Exhibit A**.
- c. The property is owned by **Midwest Decoration Co**, a business entity registered in the State of IN. I mailed a copy of the Notice by certified mail and first-class mail to the business entity's **Registered Agent, Casey S Johnson**, at the following address: **1332 Brandon Way, Fort Wayne, IN 46845**. A copy of the certified mail receipt is attached hereto as **Exhibit A**. A true and correct copy of the IN Division of Corporations record for the entity, identifying its Registered Agent, is attached hereto as **Exhibit A**.

4. On **December 30, 2025**, I posted a copy of the Notice at **146 Hercules Drive, Fort Myers Beach, FL 33931**, which is the property upon which the violation is alleged to exist. Photographs of the posted Notice, taken by me on that date, are attached hereto as **Exhibit A**.

5. On **December 30, 2025**, I posted a copy of the Notice at Town Hall, located at 6231 Estero Boulevard, Fort Myers Beach, FL 33931, which is the primary municipal government office for the Town of Fort Myers Beach. Photographs of the posted Notice, taken by me on that date, are attached hereto as **Exhibit A**.

Under penalties of perjury, I declare that I have read the foregoing Affidavit and that the facts stated in it are true and to the best of my knowledge and belief comply with Section 2-429 of the Town of Fort Myers Beach Land Development Code and Section 162.12, Florida Statutes.

**SWORN AND ATTESTED BY:**



Signature of Affiant

Printed Name: Michael J Hauserman

Title: Code Compliance Manager

The foregoing instrument was sworn to, subscribed and acknowledged before me by means of  physical presence /  online notarization, this 24th day of February, 2026, by Michael J Hauserman, who  is personally known to me  or has produced \_\_\_\_\_ as identification.

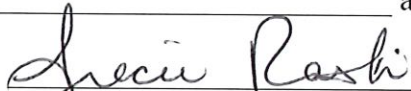

Notary Public, State of Florida

Printed Name: Tracie Raski

My Commission No.: HH 636110

My Commission Expires: 2/3/2029

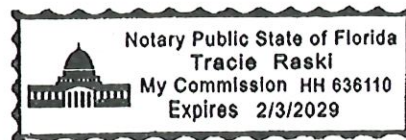

proceedings is made, which includes the testimony and evidence upon which the appeal is to be based (Section 286.0105, Florida Statutes).

For additional HEARING information, contact the Town of Fort Myers Beach Special Magistrate Clerk at (239) 478-9363.

Michael J Hauserman, CEP



---

Signature of Affiant

Code Enforcement / Code Compliance Manager  
Fort Myers Beach, Florida



Town of Fort Myers Beach  
NOTICE OF VIOLATION AND NOTICE OF CODE  
ENFORCEMENT HEARING

6231 Estero Blvd, Fort Myers Beach, FL 33931  
Phone : (239) 765-0202

\*\*\*REISSUED\*\*\*

Date: December 29, 2025

Case Number: 20240733

Owner: **Midwest Decoration Co**

Mailing Address: 15214 Tonkel Road, Leo, IN 46765

Property Address: **146 Hercules Dr, Fort Myers Beach, FL 33931**

Certified Mail# 9589071052703142133961 & 9589071052703142172502

Parcel: 29-46-24-W2-0060A.0110

YOU ARE HEREBY NOTIFIED that the undersigned Code Officer alleges that on October 15, 2025 the following violation(s) of the Florida Building Code, Eighth Edition and the Land Development Code of the Town of Fort Myers Beach, Florida, existed on the property above:

**Code Violation:** On 10/15/2025, a violation was discovered Interior and Exterior remodel, exceed the scope of the approved permit 234613. Permit 234613 has expired thus leaving the construction work conducted without the required building permits as defined in Division 3 Section 6-111 (adoption; amendments) of the FMB Code of Ordinances in adoption of the Florida Building Code.

**Relevant Codes:**

**Sec. 6-111. - Adoption; amendments.**

The Florida Building Code is hereby adopted by reference and made a part of this article, including all revisions and amendments approved in accordance with state law, with the exceptions set forth as follows:

**2023 Florida Building Code, Building, Eighth Edition**

*FBC Sec 105.1 Permits required. Any owner or owner's authorized agent who intends to construct, enlarge, alter, repair, move, demolish or change the occupancy of a building or structure, or to erect, install, enlarge, alter, repair, remove, convert or replace any impact-resistant coverings, electrical, gas, mechanical or plumbing system, the installation of which is regulated by this code, or to cause any such work to be performed, shall first make application to the building official and obtain the required permit.*

*LDC Sec 6-441 – Any owner or owner's authorized agent (hereinafter "applicant") who intends to undertake any development activity within the scope of this article, including buildings, structures and facilities exempt from the Florida Building Code, which is wholly within or partially within any flood hazard area must first make application to the floodplain administrator, and the building official, if applicable, and must obtain the required permits and approvals. No*

such permit or approval will be issued until compliance with the requirements of this article and all other applicable codes and regulations has been satisfied.

(Ord. No. 13-06, § 2, 9-3-2013; Ord. No. 16-02, § 2, 8-8-2016)

ASCE 24-14 A copy is available at [https://www.fema.gov/sites/default/files/2020-07/asce24-14\\_highlights\\_jan2015.pdf](https://www.fema.gov/sites/default/files/2020-07/asce24-14_highlights_jan2015.pdf)

**Sec. 6-501. - Design and construction of buildings, structures and facilities exempt from the Florida Building Code. Pursuant to section 6-443, buildings, structures and facilities that are exempt from the Florida Building Code, including substantial improvement or repair of substantial damage of such buildings, structures and facilities, must be designed and constructed in accordance with the flood load and flood-resistant construction requirements of ASCE 24. Structures exempt from the Florida Building Code that are not walled and roofed buildings must comply with the requirements of division 10, subdivision VII.**

**Sec. 6-525. - General requirements for other development. All development, including man-made changes to improved or unimproved real estate for which specific provisions are not specified in this article or the Florida Building Code, must:**

**(1)Be located and constructed to minimize flood damage;(2)Be anchored to prevent flotation, collapse or lateral movement resulting from hydrostatic loads, including the effects of buoyancy, during conditions of the design flood;(3)Be constructed of flood damage-resistant materials; and(4)Have mechanical, plumbing and electrical systems above the design flood elevation or meet the requirements of ASCE 24, except that minimum electric service required to address life safety and electric code requirements is permitted below the design flood elevation provided it conforms to the provisions of the electrical part of building code for wet locations.**

#### **Corrective Action Required:**

The following action is required to bring the violation(s) into compliance. Obtain / reactivate the required building permits for the unpermitted construction or restore the structure to its original permit condition. Remove any and all construction in violation of ASCE 24-14, Section 6-501, and Section 6-525.

**Compliance is required on or before: February 2, 2026**

If the referenced violations are corrected from the date of issuance of this notice, you must contact the (Emergency Services Director) Thomas Yozzo at (239) 765-0202 or (Code Manager) Michael Hauserman at (239) 478-9363

**A HEARING FOR THIS MATTER HAS BEEN SET BY THE SPECIAL MAGISTRATE CLERK FOR THE 3rd DAY OF MARCH 2026, AT 9:00 AM, AT 6231 ESTERO BLVD, FORT MYERS BEACH, FL 33931. (Fort Myers Beach Town Hall Council Chambers)**

Should all violations not be corrected and approved by the undersigned Code Enforcement Officer within the date and time specified above, you will be required to appear at the prosecution of this matter before the Town's Special Magistrate for Code Compliance, pursuant to Division 2 of Article V of Chapter 2 of the Town Land Development Code and Chapter 162, Florida Statutes. **THIS HEARING, REQUIRING YOU TO BE PRESENT, WILL BE HELD IF THE VIOLATION(S) HAVE NOT BEEN BROUGHT INTO COMPLIANCE AND APPROVED BY THE CODE ENFORCEMENT DEPARTMENT BY Wednesday, December 3, 2025 AS EVIDENCED BY THE ISSUANCE OF AN AFFIDAVIT OF COMPLIANCE BY THE**

**CODE ENFORCEMENT OFFICER.** If a violation is corrected and then recurs, or if a violation is not corrected by the time specified for correction by the code inspector, the case may be presented to the Special Magistrate even if the violation has been corrected prior to the board hearing.

The Code Officer has reason to believe that the violation(s) or the condition causing the violation(s) presents a serious threat to the public health, safety, and welfare or is irreparable or irreversible in nature, and therefore, no compliance date has been provided. This case may be presented to the Special Magistrate even if the violation(s) have been corrected prior to the hearing.

The Code Officer has reason to believe that repeat violations have been found, and therefore, no compliance date has been provided. This case may be presented to the Special Magistrate even if the repeat violation(s) have been corrected prior to the hearing.

The purpose of this Hearing is for the Special Magistrate to make "Findings of Fact" and "Conclusions of Law" relating to the violation(s) specified in the attached Violation detail and to issue an appropriate Order. The Hearing is also your opportunity to present evidence and/or contest the alleged violations, should you wish to do so. If a violation is found, the Order may require you to correct the violation(s) by a specified date. In addition, the Order may impose daily fines as per Florida Statutes Section 162.09(2)(a) of the following:

- \$250/ day per violation
- \$500/day for repeat offenses
- \$5,000 for irreversible or irreparable violations

Additionally, administrative fines may be imposed to recover all costs incurred by the Town in prosecuting this matter. If all violations are not corrected prior to the Hearing date, you may be assessed any such costs. **THE IMPOSITION OF FINES AND/OR COSTS MAY RESULT IN A LIEN AGAINST YOU AND YOUR PROPERTY.**

You should be aware that if the alleged violation(s) is/are corrected prior to the Hearing and recurs within five (5) years from the date of the original Notice of Violation, the case may be presented to the Special Magistrate as a Recurring Violation even if the violation is subsequently corrected.

You have the right to be represented by an attorney and to respond and present evidence and witnesses at the Hearing. If you wish to be represented by an attorney, your attorney **MUST** notify the Special Magistrate's Clerk in writing at least five (5) working days before the Hearing.

You may also have other rights which are set forth in Division 2 of Article V of Chapter 2 of the Town Land Development Code. If a person decides to appeal any decision with respect to any matter considered at this Hearing, such person will need to ensure that a verbatim record of the

9589 0710 5270 3142 1343 26

U.S. Postal Service™ **CERTIFIED MAIL® RECEIPT**  
Domestic Mail Only

07H  
20240730

For delivery information, visit our website at [www.usps.com](http://www.usps.com)™.

**OFFICIAL USE**

Certified Mail Fee	\$
Extra Services & Fees (check box, add fee as appropriate)	
<input type="checkbox"/> Return Receipt (hardcopy)	\$
<input type="checkbox"/> Return Receipt (electronic)	\$
<input type="checkbox"/> Certified Mail Restricted Delivery	\$
<input type="checkbox"/> Adult Signature Required	\$
<input type="checkbox"/> Adult Signature Restricted Delivery	\$

12/ Postmark Here  
30  
25 mt

Postage	\$
Total Postage and Fees	\$

Sent To	MIDWEST DECORATION CO
Street and Apt. No., or P.O. Box No.	15214 TONKEL RD
City, State, ZIP+4®	LEO IN 46765

PS Form 3800, January 2023 PSN 7530-02-000-9047 See Reverse for Instructions

9589 0710 5270 3142 1343 33

U.S. Postal Service™ **CERTIFIED MAIL® RECEIPT**  
Domestic Mail Only

20240733  
07H

For delivery information, visit our website at [www.usps.com](http://www.usps.com)™.

**OFFICIAL USE**

Certified Mail Fee	\$
Extra Services & Fees (check box, add fee as appropriate)	
<input type="checkbox"/> Return Receipt (hardcopy)	\$
<input type="checkbox"/> Return Receipt (electronic)	\$
<input type="checkbox"/> Certified Mail Restricted Delivery	\$
<input type="checkbox"/> Adult Signature Required	\$
<input type="checkbox"/> Adult Signature Restricted Delivery	\$

12/30/25  
Postmark Here  
mt

Postage	\$
Total Postage and Fees	\$

Sent To	MIDWEST DECORATION CO
Street and Apt. No., or P.O. Box No.	C/O Casey S. Johnson, RA
City, State, ZIP+4®	1332 Brandon Way Fort Wayne, IN 46845

PS Form 3800, January 2023 PSN 7530-02-000-9047 See Reverse for Instructions



MIDWEST DECORATION CO  
15214 TONKEL RD  
LEO IN 46765



MIDWEST DECORATION CO  
C/O Casey S. Johnson, RA  
1332 Brandon Way  
Fort Wayne, IN 46845



MIDWEST DECORATION CO  
146 HERCULES DR  
FORT MYERS BEACH FL 33931



**Town of Fort Myers Beach**  
**NOTICE OF VIOLATION AND NOTICE OF CODE**  
**ENFORCEMENT HEARING**  
 6231 Estero Blvd, Fort Myers Beach, FL 33914  
 Phone: (239) 765-0302

Permit 234813  
 07-

**REISSUED**  
 Date: December 29, 2025

Case Number: 20240733

Owner: Midwest Decoration Co  
 Mailing Address: 15214 Tonkel Road, Leo, IN 46765  
 Property Address: 146 Hercules Dr, Fort Myers Beach, FL 33931  
 Certified Mail# 9589071052703142133961 & 9589071052703142172502  
 Parcel: 29-46-24-W2-0060A.0110

YOU ARE HEREBY NOTIFIED that the undersigned Code Officer alleges that on October 15, 2025 the following violation(s) of the Florida Building Code, Eighth Edition and its Land Development Code of the Town of Fort Myers Beach, Florida, existed on the property above:

**Code Violation:** On 10/15/2025, a violation was discovered Interior and Exterior removal exceed the scope of the approved permit 234813. Permit 234813 has expired thus leaving the contractor work conducted without the required building permits as defined in Division 3 Section 2-01 (Adoption, amendments) of the FMB Code of Ordinances in adoption of the Florida Building Code.

**Relevant Codes:**  
 Sec. 6-111. - Adoption; amendments.

The Florida Building Code is hereby adopted by reference and made a part of the code making all revisions and amendments approved in accordance with state law, with the exception of any

2023 Florida Building Code, Building, Eighth Edition  
 FBC Sec 105.1 Permits required. Any owner or owner's authorized agent who intends to construct, enlarge, alter, repair, move, demolish or change the occupancy of a building or structure, or to erect, install, enlarge, alter, repair, remove, connect or disconnect any heating, air conditioning, electrical, gas, mechanical or plumbing system, or any combination thereof, which is regulated by this code, or to cause any such work to be performed, shall first make application to the building official and obtain the required permit.  
 LDC Sec 6-441 - Any owner or owner's authorized agent (hereinafter referred to as the contractor) who intends to undertake any development activity within the scope of this code, shall first make application to the building official and obtain the required permit. No structures and facilities exempt from the Florida Building Code, shall be constructed within any flood hazard area must first obtain the required permit from the building official, if applicable.

Staples

1  
 4  
 6

Dec 30, 2025 9:59:03 AM  
 Fort Myers Beach



Compliance is required on or before: January 23, 2026

Posted 12.30.25  
MT

Town of Fort Myers Beach  
NOTICE OF VIOLATION AND NOTICE OF CODE  
ENFORCEMENT HEARING  
6231 Estero Blvd, Fort Myers Beach, FL 33931  
Phone : (239) 766-2202

\*\*\*REISSUED\*\*\*

Date: December 29, 2025

Case Number: 20240733

Owner: Midwest Decoration Co  
Mailing Address: 15214 Tankel Road, Leo, IN 46765  
Property Address: 146 Hercules Dr, Fort Myers Beach, FL 33931  
Certified Mail# 9589071052703142133961 & 9589071052703142172502  
Parcel: 29-46-24-W2-0060A.0110

YOU ARE HEREBY NOTIFIED that the undersigned Code Officer alleges that on October 15, 2025 the following violation(s) of the Florida Building Code, Eighth Edition and the Land Development Code of the Town of Fort Myers Beach, Florida, existed on the property above:

**Code Violation:** On 10/16/2025, a violation was discovered Interior and Exterior remodel, exceed the scope of the approved permit 234813. Permit 234813 has expired thus leaving the construction work conducted without the required building permits as defined in Division 3 Section 6-111 (adoption; amendments) of the FMB Code of Ordinances in adoption of the Florida Building Code.

**Relevant Codes:**

**Sec. 6-111. - Adoption; amendments.**

The Florida Building Code is hereby adopted by reference and made a part of this article, including all revisions and amendments approved in accordance with state law, with the exceptions set forth as follows:

**2023 Florida Building Code, Building, Eighth Edition**

**FBC Sec 105.1 Permits required.** Any owner or owner's authorized agent who intends to construct, enlarge, alter, repair, move, demolish or change the occupancy of a building or structure, or to erect, install, enlarge, alter, repair, remove, convert or replace any impact-resistant coverings, electrical, gas, mechanical or plumbing system, the installation of which is regulated by this code, or to cause any such work to be performed, shall first make application to the building official and obtain the required permit.

**LDC Sec 6-441 -** Any owner or owner's authorized agent (hereinafter "applicant") who intends to undertake any development activity within the scope of this article, including buildings, structures and facilities exempt from the Florida Building Code, which is wholly within or partially within any flood hazard area must first make application to the floodplain administrator and the building official, if applicable, and must obtain the required permits and approvals.

Dec 30, 2025 8:57:00 AM  
Fort Myers Beach

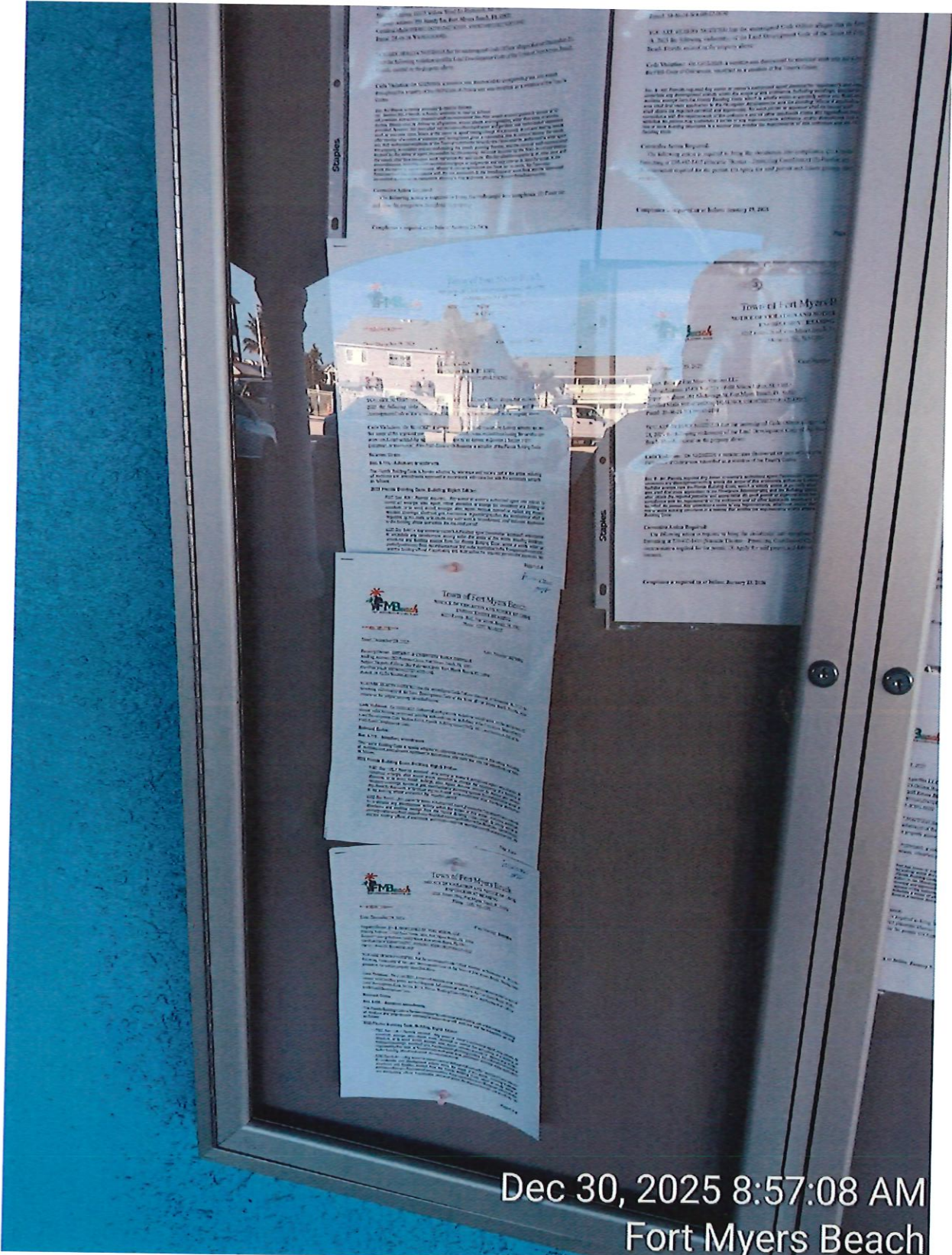

Dec 30, 2025 8:57:08 AM  
Fort Myers Beach



# Property Data

STRAP: 29-46-24-W2-0060A.0110 Folio ID: 10229746

Tax Roll Value Letter 2025

Generated on 2/24/2026 10:14 AM

### Owner Of Record - Sole Owner [\[Change Mailing Address\]](#)



MIDWEST DECORATION CO  
15214 TONKEL RD  
LEO IN 46765

### Site Address

Site Address maintained by [E911 Program Addressing](#)

146 HERCULES DR  
FORT MYERS BEACH FL 33931

### Property Description

Do not use for legal documents!



HERCULES PARK BLK A PB 5 PG 22 LOTS 11 + 12

[View Recorded Plat at LeeClerk.org](#) - Use this link to do an Official Records search on the Lee County Clerk of Courts website, using 5 and 22 for the book and page numbers.

### Attributes and Location Details

Total Bedrooms / Bathrooms	3 / 3.0
Gross Living Area	1,678
1st Year Building on Tax Roll	1958
Historic Designation	No

<b>Township</b>	<b>Range</b>	<b>Section</b>	<b>Block</b>	<b>Lot</b>
46	24E	29	0060A	0110
<b>Municipality</b>	<b>Latitude</b>	<b>Longitude</b>		
Town of Fort Myers Beach	26.4404	-81.92379		

[View Parcel on Google Maps](#)

### [ Tax Map Viewer ] [ View Comparables ]



### [ Pictometry Aerial Viewer ]

### Image of Structure



◀ Photo Date February of 2013 ▶  View other photos

Last Inspection Date: 04/16/2018

## Property Values / Exemptions / TRIM Notices

Generated on 2/24/2026 10:14 AM

No existing exemptions found for this property.

TRIM Notices	Tax Year	Just	Land	Market Assessed	Capped Assessed	Exemptions	Classified Use	Taxable
<a href="#">2025 / Additional Info</a>	2025 (Final Value)	613,611	613,601	613,611	613,611	0	0	613,611
<a href="#">2024 / Additional Info</a>	2024 (Final Value)	773,706	773,696	773,706	773,706	0	0	773,706
<a href="#">2023 / Additional Info</a>	2023 (Corrected Value)	442,811	442,801	442,811	442,811	0	0	442,811

**BUSINESS INFORMATION**  
DIEGO MORALES  
INDIANA SECRETARY OF STATE  
02/24/2026 10:15 AM

**Business Details**

Business Name: **MIDWEST DECORATION CO.** Business ID: **201812061292509**  
Entity Type: **Domestic For-Profit Corporation** Business Status: **Active**  
Creation Date: **12/06/2018** Inactive Date:  
Principal Office Address: **15214 Tonkel Road, Leo, IN, 46765, USA** Expiration Date: **Perpetual**  
Jurisdiction of Formation: **Indiana** Business Entity Report Due Date: **12/31/2026**  
Years Due:

**Governing Person Information**

Title	Name	Address
President	Casey S Johnson	1332 Brandon Way, Fort Wayne, IN, 46845, USA
President	Casey Johnson	1332 Brandon Way, Fort Wayne, IN, 46845, USA
President	Casey Johnson	1332 Brandon Way, Fort Wayne, IN, 46845, USA

**Incorporators Information**

Name	Title	Address
Charles J Heiny	Incorporator	444 East Main Street, Fort Wayne, IN, 46802, USA

**Registered Agent Information**

Type: **Individual**  
Name: **Casey S. Johnson**  
Address: **1332 Brandon Way, Fort Wayne, IN, 46845, USA**

CODE COMPLIANCE SPECIAL MAGISTRATE  
THE TOWN OF FORT MYERS BEACH, FLORIDA

TOWN OF FORT MYERS BEACH,  
a Florida municipal corporation,

Petitioner,

vs.

FMB CASE NO. 20240733

MIDWEST DECORATION CO

Respondent.

\_\_\_\_\_ /

ORDER OF CONTINUANCE

The undersigned hereby gives notice that the Honorable Judge John G. Van Laningham continued a hearing in the above case at the Fort Myers Beach Council Chambers from Tuesday, March 3, 2026. The continued hearing will be held on **Tuesday, May 5, 2026, at 9:00 a.m.** at the Town of Fort Myers Beach Town Hall located at 6231 Estero Boulevard, Fort Myers Beach, Lee County, Florida.

Ordered this \_\_\_\_ day of March, 2026.

\_\_\_\_\_  
John G. Van Laningham,  
Special Magistrate

**CERTIFICATE OF SERVICE**

I, the undersigned, hereby certify that true and correct copy of the Order was sent by U.S. Mail on the \_\_\_ day of \_\_\_\_\_ 2026, to:

MIDWEST DECORATION CO  
15214 TONKEL RD  
LEO, IN 46865

Nancy Stuparich: [nstuparich@voselaw.com](mailto:nstuparich@voselaw.com)  
Michael Hauserman: [Michael.Hauserman@fmbgov.com](mailto:Michael.Hauserman@fmbgov.com)  
Amy Baker: [amy@fmbgov.com](mailto:amy@fmbgov.com)

I certify this document to be a true and correct copy of the original on file in Town Hall, Fort Myers Beach, State of Florida, County of Lee.

BY: \_\_\_\_\_  
Town Clerk and Clerk to the Special Magistrate

Dated: \_\_\_\_\_

APPEAL: An aggrieved party may appeal an Order of the Special Magistrate of the Town of Fort Myers Beach to the Lee County Circuit Court. The appeal shall be limited to appellate review of the record created before the Special Magistrate. An appeal shall be filed within thirty (30) days of the execution of the Order to be appealed.

PAYMENT OF ADMINISTRATIVE COSTS, LIENS OR FINES: Checks should be made payable to "Town of Fort Myers Beach," include the case number and mail to:

Town of Fort Myers Beach  
Attention: Code Enforcement  
6231 Estero Boulevard  
Fort Myers Beach, FL 33931

**Property Address and Owner:**

**Hearing Date: March 3, 2026**

Property Owner: B + B Properties of Fort Myers, LLC (The Beach Bar)  
FMB Case # 20250800  
Property Address: 1668 I Street  
Violation: Lack of current valid building permit and building code deficiencies.  
Officer: M. Hauserman  
Request to Continue to May 5, 2026 Hearings (Working with Building Department)

**Subject:**

**Code Section:**

**Reference Number:**

**Strap Number:**

**Officer:**

---

**Narrative:**

Working with Permitting on listed violations. Rescheduled per conversation with Frankie Kropacek and email request from law firm.

**Attachments:**

1. 20250800\_Email Confirming Cont Req 1668 I Street
2. 20250800\_1668 I Street\_ Exhibit B\_Email Chain with Notice of Representation
3. 20250800\_1668 I Street\_ Exhibit A\_Notice of Violation and Hearing Affidavit Ownership
4. 20250800\_1668 I Street\_Draft Notice of Continued Hearing

**Town Recommendations:**

**Town Approvals:**

_____	Date: February 25, 2026
Michael Hauserman, Code Compliance Manager	
_____	Date: February 25, 2026
Thomas Yozzo, Emergency Services Director	
	
_____	Date: February 25, 2026
Traci Kohler, Deputy Town Manager	
_____	Date: February 25, 2026
nancy stuparich, Town Attorney	
_____	Date: February 25, 2026
Lizzette Roman, Town Clerk Administrative Coordinator	
_____	Date: February 25, 2026
Amy Baker, Town Clerk	

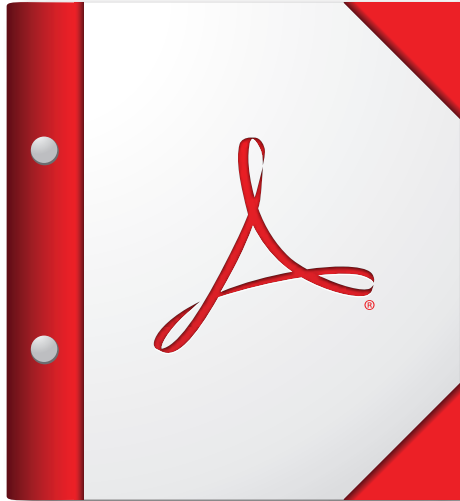

**For the best experience, open this PDF portfolio in  
Acrobat X or Adobe Reader X, or later.**

[Get Adobe Reader Now!](#)

# EXHIBIT B

## Email chain

- **Notice of Representation**
- **Requests and Agreements of Continuances**

## Michael Hauserman

---

**From:** Colten Thomas <Colten.Thomas@henlaw.com>  
**Sent:** Monday, February 16, 2026 1:46 PM  
**To:** Michael Hauserman; Frankie Kropacek  
**Cc:** apd@studioad.net  
**Subject:** RE: Special Magistrate Clerk 1668 I Street Case #20250800

**CAUTION:** This email originated from outside of Town of Fort Myers Beach. Do not click links or open attachments unless you know the content is safe.

---

Good afternoon, all:

Received, thank you. Please advise if/when the continuation is confirmed and an amended notice is generated, and I will pass the update along to my client.

At your earliest convenience, please also advise if the Town has capacity to touch base with The Beach Bar's design and construction team to confirm receipt and review of their portal submissions/remediation plan. We are relying on the Town's acknowledgement and approval to expedite the project(s), and my client is eager to resolve this.

If there is anything we can do to facilitate things on our end, please advise.

Thank you,

**Colten Thomas**  
Attorney at Law  
Henderson, Franklin, Starnes & Holt, P.A.  
1715 Monroe Street  
Fort Myers, FL 33901  
Direct Dial: 239.344.1213  
Fax: 239.344.1213  
Colten.Thomas@henlaw.com  
www.henlaw.com  
Blogs: www.swflbusinessandipblog.com • www.legalscoopswflre.com



---

### CONFIDENTIALITY STATEMENT

Henderson, Franklin, Starnes & Holt, P.A.

The information contained in this transmission may contain privileged and confidential information. It is intended only for the us the person(s) named above. If you are not the intended recipient, you are hereby notified that any review, dissemination, distribu or duplication of this communication is strictly prohibited. If you are not the intended recipient, please contact the sender by repl mail and destroy all copies of the original message.

---

**From:** Michael Hauserman <Michael.Hauserman@fmbgov.com>  
**Sent:** Thursday, February 12, 2026 1:33 PM  
**To:** Colten Thomas <Colten.Thomas@henlaw.com>  
**Cc:** Frankie Kropacek <fkropacek@fmbgov.com>; apd@studioad.net  
**Subject:** RE: Special Magistrate Clerk 1668 I Street Case #20250800  
**Importance:** High

Unless there are any objections, the Town is going to request this case be continued to the May 5, 2026 hearing to allow for compliance.

**Michael J.  
Hauserman, CEP**  
*Code Compliance Manager*  
Town of Fort Myers Beach  
6231 Estero Blvd  
Fort Myers Beach, FL 33931  
Phone: (239) 478-9363



---

**FMBgov.com**



---

**From:** Frankie Kropacek <[fkropacek@fmbgov.com](mailto:fkropacek@fmbgov.com)>  
**Sent:** Thursday, February 5, 2026 7:53 AM  
**To:** Michael Hauserman <[Michael.Hauserman@fmbgov.com](mailto:Michael.Hauserman@fmbgov.com)>  
**Cc:** Thomas Yozzo <[tyozzo@fmbgov.com](mailto:tyozzo@fmbgov.com)>  
**Subject:** RE: Special Magistrate Clerk 1668 I Street Case #20250800

Good morning, Michael.

Before you respond please see Tom and I to discuss this please .....

Thank You

**Frankie Kropacek**  
*Community Development  
Director*  
Town of Fort Myers Beach  
6231 Estero Blvd  
Fort Myers Beach, FL 33931  
Phone: (239) 765-0202



---

**FMBgov.com**



---

**From:** Colten Thomas <[Colten.Thomas@henlaw.com](mailto:Colten.Thomas@henlaw.com)>  
**Sent:** Wednesday, February 4, 2026 5:04 PM  
**To:** Michael Hauserman <[Michael.Hauserman@fmbgov.com](mailto:Michael.Hauserman@fmbgov.com)>  
**Cc:** Frankie Kropacek <[fkropacek@fmbgov.com](mailto:fkropacek@fmbgov.com)>; Albert Dambrose <[apd@studioad.net](mailto:apd@studioad.net)>  
**Subject:** RE: Special Magistrate Clerk 1668 I Street Case #20250800

**CAUTION:** This email originated from outside of Town of Fort Myers Beach. Do not click links or open attachments unless you know the content is safe.

---

Good afternoon, Mr. Hauserman:

I hope this email finds you well. I am writing to follow up on the above-mentioned Code case, in light of the ongoing compliance activity at 1668 I Street.

As you know, my client has been working diligently to address each item raised by the Town. Specifically, by submitting an updated V-zone certificate, permit/design revisions, and other remediation plans for staff's review and approval in early December. However, these items have not yet been assigned to review. It follows that the design and construction team cannot proceed with handling until plans are approved; nor can they move forward with the second phase of remediation.

Given the circumstances—and in consideration of the unique hardship, holiday backlog, and time-intensive repairs—we kindly request an additional extension to the compliance deadline/rescheduled hearing date before the Town's Special Magistrate, consistent with Section 2-424(b) of the Town's Land Development Code.

Please advise if this is acceptable, and if you need any additional information from us to facilitate a review/approval of my client's intended plans. Project architect Albert Dambrose, copied here, is likely the best point of contact for any technical questions—but I am also available to assist as needed.

Thank you for your time, assistance, and understanding.

All the best,

**Colten Thomas**  
Attorney at Law  
Henderson, Franklin, Starnes & Holt, P.A.  
1715 Monroe Street  
Fort Myers, FL 33901  
Direct Dial: 239.344.1213  
Fax: 239.344.1213  
[Colten.Thomas@henlaw.com](mailto:Colten.Thomas@henlaw.com)  
[www.henlaw.com](http://www.henlaw.com)  
Blogs: [www.swflbusinessandipblog.com](http://www.swflbusinessandipblog.com) • [www.legalscoopsfwflre.com](http://www.legalscoopsfwflre.com)



---

## CONFIDENTIALITY STATEMENT

Henderson, Franklin, Starnes & Holt, P.A.

The information contained in this transmission may contain privileged and confidential information. It is intended only for the us the person(s) named above. If you are not the intended recipient, you are hereby notified that any review, dissemination, distribu or duplication of this communication is strictly prohibited. If you are not the intended recipient, please contact the sender by repl mail and destroy all copies of the original message.

---

**From:** Colten Thomas <[Colten.Thomas@henlaw.com](mailto:Colten.Thomas@henlaw.com)>  
**Sent:** Tuesday, December 30, 2025 8:59 AM  
**To:** Michael Hauserman <[Michael.Hauserman@fmbgov.com](mailto:Michael.Hauserman@fmbgov.com)>  
**Cc:** Kirsten Shultz <[Kirsten.Shultz@henlaw.com](mailto:Kirsten.Shultz@henlaw.com)>; Frankie Kropacek <[fkropacek@fmbgov.com](mailto:fkropacek@fmbgov.com)>  
**Subject:** Re: Special Magistrate Clerk 1668 I Street Case #20250800

Good Morning:

Received, thank you. I will pass this information on to my client and will follow up as needed.

We appreciate your assistance and consideration in connection with this matter.

Best,

---

**From:** Michael Hauserman <[Michael.Hauserman@fmbgov.com](mailto:Michael.Hauserman@fmbgov.com)>  
**Sent:** Monday, December 29, 2025 4:12:45 PM  
**To:** Colten Thomas <[Colten.Thomas@henlaw.com](mailto:Colten.Thomas@henlaw.com)>  
**Cc:** Kirsten Shultz <[Kirsten.Shultz@henlaw.com](mailto:Kirsten.Shultz@henlaw.com)>; Frankie Kropacek <[fkropacek@fmbgov.com](mailto:fkropacek@fmbgov.com)>  
**Subject:** RE: Special Magistrate Clerk 1668 I Street Case #20250800

Thank you for your efforts to come into compliance. I have reissued the notice. (see attached) Extension granted with compliance date by 2/2/26 or a hearing on 3/3/26 at 9am.

**Michael J.  
Hauserman, CEP**  
*Code Compliance Manager*  
Town of Fort Myers Beach  
6231 Estero Blvd  
Fort Myers Beach, FL 33931  
Phone: (239) 478-9363



---

**FMBgov.com**



---

**From:** Michael Hauserman <[Michael.Hauserman@fmbgov.com](mailto:Michael.Hauserman@fmbgov.com)>  
**Sent:** Monday, December 29, 2025 11:49 AM  
**To:** [Colten.Thomas@henlaw.com](mailto:Colten.Thomas@henlaw.com)  
**Cc:** Lizzette Roman <[Lroman@fmbgov.com](mailto:Lroman@fmbgov.com)>; Amy Baker <[Amy@fmbgov.com](mailto:Amy@fmbgov.com)>; [Kirsten.Shultz@henlaw.com](mailto:Kirsten.Shultz@henlaw.com); Frankie

Kropacek <[fkropacek@fmbgov.com](mailto:fkropacek@fmbgov.com)>

**Subject:** RE: Special Magistrate Clerk 1668 I Street Case #20250800

I see that your permit is currently in review/revision. Due to your contact and efforts toward compliance, I will be reissuing your Notice of Hearing for the March 2026 hearing at 9am. I will email you a copy by the end of the day on Tuesday. Please keep me updated on your compliance efforts.

If you have any questions or concerns, please let me know.

**Michael J.  
Hauserman, CEP**  
*Code Compliance Manager*  
Town of Fort Myers Beach  
6231 Estero Blvd  
Fort Myers Beach, FL 33931  
Phone: (239) 478-9363



---

**FMBgov.com**



---

**From:** Amy Baker <[Amy@fmbgov.com](mailto:Amy@fmbgov.com)>  
**Sent:** Monday, December 29, 2025 11:05 AM  
**To:** Michael Hauserman <[Michael.Hauserman@fmbgov.com](mailto:Michael.Hauserman@fmbgov.com)>  
**Cc:** Lizzette Roman <[Lroman@fmbgov.com](mailto:Lroman@fmbgov.com)>  
**Subject:** FW: Special Magistrate Clerk

Please see below request

**Amy Baker**  
*Town Clerk*  
Town of Fort Myers Beach  
6231 Estero Blvd  
Fort Myers Beach, FL  
33931  
Phone: (239) 765-0202



---

**FMBgov.com**



As of January 1, 2024 the Town has implemented online records request. Please consider submitting your request through the portal. Any requests received via email will be transferred by staff to this portal, with all responses coming from "Town of Fort Myers Beach Public Records"

<https://fortmyersbeachfl.nextrequest.com/>

---

**From:** Colten Thomas <[Colten.Thomas@henlaw.com](mailto:Colten.Thomas@henlaw.com)>  
**Sent:** Tuesday, December 23, 2025 4:35 PM  
**To:** Amy Baker <[Amy@fmbgov.com](mailto:Amy@fmbgov.com)>

Cc: Kirsten Shultz <[Kirsten.Shultz@henlaw.com](mailto:Kirsten.Shultz@henlaw.com)>; Lizzette Roman <[Lroman@fmbgov.com](mailto:Lroman@fmbgov.com)>

Subject: RE: Special Magistrate Clerk

**CAUTION:** This email originated from outside of Town of Fort Myers Beach. Do not click links or open attachments unless you know the content is safe.

Good afternoon, Amy:

Thank you for the clarification, and for the quick response!

My name is Colten Thomas, and I represent B + B Properties of Fort Myers, LLC, in connection with the Notice of Violation issued at 1668 I Street, Fort Myers Beach, FL 33931 (Case No. 20250800).

We are just reaching out to confirm that the Special Magistrate's meeting agenda/calendar for January 7, 2026, has been updated to reflect that the original hearing for 20250800 was **cancelled/postponed**. I already spoke with Frankie Kropacek last week, who confirmed with Tom Yozzo—but I just wanted to confirm before the holidays ramp up.

Additionally—if/when the hearing is rescheduled—please allow this email to serve as written notice that I will be attending on behalf of B + B Properties. (I do not foresee this matter requiring a future hearing, but I don't want to miss that 5-day notice requirement.)

Thank you! I hope you have a fantastic Christmas and Happy New Year!

Best,

**Colten Thomas**

Attorney at Law

Henderson, Franklin, Starnes & Holt, P.A.

1715 Monroe Street

Fort Myers, FL 33901

Direct Dial: 239.344.1213

Fax: 239.344.1213

[Colten.Thomas@henlaw.com](mailto:Colten.Thomas@henlaw.com)

[www.henlaw.com](http://www.henlaw.com)

Blogs: [www.swflbusinessandipblog.com](http://www.swflbusinessandipblog.com) • [www.legalscoopswflre.com](http://www.legalscoopswflre.com)



---

## CONFIDENTIALITY STATEMENT

Henderson, Franklin, Starnes & Holt, P.A.

The information contained in this transmission may contain privileged and confidential information. It is intended only for the us the person(s) named above. If you are not the intended recipient, you are hereby notified that any review, dissemination, distribu or duplication of this communication is strictly prohibited. If you are not the intended recipient, please contact the sender by repl mail and destroy all copies of the original message.

---

**From:** Amy Baker <[Amy@fmbgov.com](mailto:Amy@fmbgov.com)>  
**Sent:** Tuesday, December 23, 2025 4:07 PM  
**To:** Kirsten Shultz <[Kirsten.Shultz@henlaw.com](mailto:Kirsten.Shultz@henlaw.com)>  
**Cc:** Lizzette Roman <[Lroman@fmbgov.com](mailto:Lroman@fmbgov.com)>  
**Subject:** RE: Special Magistrate Clerk

Kirsten,

I am technically the Clerk to the Special Magistrate for the Town, although my Lizzette Roman attends the hearings.

Is there something I can help you with? I have also copied Lizzette in the email.

Have a wonderful Christmas!

## Amy Baker

*Town Clerk*  
Town of Fort Myers Beach  
6231 Estero Blvd  
Fort Myers Beach, FL  
33931  
Phone: (239) 765-0202



[FMBgov.com](http://FMBgov.com)



As of January 1, 2024 the Town has implemented online records request. Please consider submitting your request through the portal. Any requests received via email will be transferred by staff to this portal, with all responses coming from "Town of Fort Myers Beach Public Records"

<https://fortmyersbeachfl.nextrequest.com/>

---

**From:** Kirsten Shultz <[Kirsten.Shultz@henlaw.com](mailto:Kirsten.Shultz@henlaw.com)>  
**Sent:** Tuesday, December 23, 2025 3:38 PM  
**To:** Amy Baker <[Amy@fmbgov.com](mailto:Amy@fmbgov.com)>  
**Subject:** Special Magistrate Clerk

**CAUTION:** This email originated from outside of Town of Fort Myers Beach. Do not click links or open attachments unless you know the content is safe.

---

Good Afternoon: Sorry to bother you, but does the Special Magistrate Clerk have an email address? I have called 239-765-4222 and the mailbox is full. Thank you for any assistance.

**Kirsten Shultz**  
Legal Assistant  
Henderson, Franklin, Starnes & Holt, P.A.  
1715 Monroe Street  
Fort Myers, FL 33901  
Direct Dial: 239.344.1208

Fax: 239.344.1208

Kirsten.Shultz@henlaw.com

www.henlaw.com

Blogs: [www.swflbusinessandipblog.com](http://www.swflbusinessandipblog.com) • [www.legalscoopswflre.com](http://www.legalscoopswflre.com)



---

## CONFIDENTIALITY STATEMENT

Henderson, Franklin, Starnes & Holt, P.A.

The information contained in this transmission may contain privileged and confidential information. It is intended only for the use of the person(s) named above. If you are not the intended recipient, you are hereby notified that any review, dissemination, distribution or duplication of this communication is strictly prohibited. If you are not the intended recipient, please contact the sender by reply mail and destroy all copies of the original message.

Note: Florida has a very broad public records law. Most communication(s) to or from Fort Myers Beach officials regarding Town business are public records available to the public and media upon request. Your email communications and email address may be subject to public disclosure.

Note: Florida has a very broad public records law. Most communication(s) to or from Fort Myers Beach officials regarding Town business are public records available to the public and media upon request. Your email communications and email address may be subject to public disclosure.

Note: Florida has a very broad public records law. Most communication(s) to or from Fort Myers Beach officials regarding Town business are public records available to the public and media upon request. Your email communications and email address may be subject to public disclosure.

Note: Florida has a very broad public records law. Most communication(s) to or from Fort Myers Beach officials regarding Town business are public records available to the public and media upon request. Your email communications and email address may be subject to public disclosure.

Note: Florida has a very broad public records law. Most communication(s) to or from Fort Myers Beach officials regarding Town business are public records available to the public and media upon request. Your email communications and email address may be subject to public disclosure.

Note: Florida has a very broad public records law. Most communication(s) to or from Fort Myers Beach officials regarding Town business are public records available to the public and media upon request. Your email communications and email address may be subject to public disclosure.

Note: Florida has a very broad public records law. Most communication(s) to or from Fort Myers Beach officials regarding Town business are public records available to the public and media upon request. Your email communications and email address may be subject to public disclosure.

## Michael Hauserman

---

**From:** Michael Hauserman  
**Sent:** Monday, December 29, 2025 3:13 PM  
**To:** Colten.Thomas@henlaw.com  
**Cc:** Kirsten.Shultz@henlaw.com; Frankie Kropacek  
**Subject:** RE: Special Magistrate Clerk 1668 I Street Case #20250800  
**Attachments:** 20251229145528518.pdf

Thank you for your efforts to come into compliance. I have reissued the notice. (see attached) Extension granted with compliance date by 2/2/26 or a hearing on 3/3/26 at 9am.

**Michael J.  
Hauserman, CEP**  
*Code Compliance Manager*  
Town of Fort Myers Beach  
6231 Estero Blvd  
Fort Myers Beach, FL 33931  
Phone: (239) 478-9363



---

**FMBgov.com**



---

**From:** Michael Hauserman <Michael.Hauserman@fmbgov.com>  
**Sent:** Monday, December 29, 2025 11:49 AM  
**To:** Colten.Thomas@henlaw.com  
**Cc:** Lizzette Roman <Lroman@fmbgov.com>; Amy Baker <Amy@fmbgov.com>; Kirsten.Shultz@henlaw.com; Frankie Kropacek <fkropacek@fmbgov.com>  
**Subject:** RE: Special Magistrate Clerk 1668 I Street Case #20250800

I see that your permit is currently in review/revision. Due to your contact and efforts toward compliance, I will be reissuing your Notice of Hearing for the March 2026 hearing at 9am. I will email you a copy by the end of the day on Tuesday. Please keep me updated on your compliance efforts.

If you have any questions or concerns, please let me know.

**Michael J.  
Hauserman, CEP**  
*Code Compliance Manager*  
Town of Fort Myers Beach  
6231 Estero Blvd



Fort Myers Beach, FL 33931  
Phone: (239) 478-9363

FMBgov.com



---

**From:** Amy Baker <[Amy@fmbgov.com](mailto:Amy@fmbgov.com)>  
**Sent:** Monday, December 29, 2025 11:05 AM  
**To:** Michael Hauserman <[Michael.Hauserman@fmbgov.com](mailto:Michael.Hauserman@fmbgov.com)>  
**Cc:** Lizzette Roman <[Lroman@fmbgov.com](mailto:Lroman@fmbgov.com)>  
**Subject:** FW: Special Magistrate Clerk

Please see below request

## Amy Baker

*Town Clerk*  
Town of Fort Myers Beach  
6231 Estero Blvd  
Fort Myers Beach, FL  
33931  
Phone: (239) 765-0202



FMBgov.com



As of January 1, 2024 the Town has implemented online records request. Please consider submitting your request through the portal. Any requests received via email will be transferred by staff to this portal, with all responses coming from "Town of Fort Myers Beach Public Records"

<https://fortmyersbeachfl.nextrequest.com/>

---

**From:** Colten Thomas <[Colten.Thomas@henlaw.com](mailto:Colten.Thomas@henlaw.com)>  
**Sent:** Tuesday, December 23, 2025 4:35 PM  
**To:** Amy Baker <[Amy@fmbgov.com](mailto:Amy@fmbgov.com)>  
**Cc:** Kirsten Shultz <[Kirsten.Shultz@henlaw.com](mailto:Kirsten.Shultz@henlaw.com)>; Lizzette Roman <[Lroman@fmbgov.com](mailto:Lroman@fmbgov.com)>  
**Subject:** RE: Special Magistrate Clerk

**CAUTION:** This email originated from outside of Town of Fort Myers Beach. Do not click links or open attachments unless you know the content is safe.

Good afternoon, Amy:

Thank you for the clarification, and for the quick response!

My name is Colten Thomas, and I represent B + B Properties of Fort Myers, LLC, in connection with the Notice of Violation issued at 1668 I Street, Fort Myers Beach, FL 33931 (Case No. 20250800).

We are just reaching out to confirm that the Special Magistrate's meeting agenda/calendar for January 7, 2026, has been updated to reflect that the original hearing for 20250800 was **cancelled/postponed**. I already spoke

with Frankie Kropacek last week, who confirmed with Tom Yozzo—but I just wanted to confirm before the holidays ramp up.

Additionally—if/when the hearing is rescheduled—please allow this email to serve as written notice that I will be attending on behalf of B + B Properties. (I do not foresee this matter requiring a future hearing, but I don't want to miss that 5-day notice requirement.)

Thank you! I hope you have a fantastic Christmas and Happy New Year!

Best,

**Colten Thomas**

Attorney at Law

Henderson, Franklin, Starnes & Holt, P.A.

1715 Monroe Street

Fort Myers, FL 33901

Direct Dial: 239.344.1213

Fax: 239.344.1213

Colten.Thomas@henlaw.com

www.henlaw.com

Blogs: [www.swflbusinessandipblog.com](http://www.swflbusinessandipblog.com) • [www.legalscoopsfwflre.com](http://www.legalscoopsfwflre.com)



---

**CONFIDENTIALITY STATEMENT**

Henderson, Franklin, Starnes & Holt, P.A.

The information contained in this transmission may contain privileged and confidential information. It is intended only for the use of the person(s) named above. If you are not the intended recipient, you are hereby notified that any review, dissemination, distribution or duplication of this communication is strictly prohibited. If you are not the intended recipient, please contact the sender by reply mail and destroy all copies of the original message.

---

**From:** Amy Baker <[Amy@fmbgov.com](mailto:Amy@fmbgov.com)>  
**Sent:** Tuesday, December 23, 2025 4:07 PM  
**To:** Kirsten Shultz <[Kirsten.Shultz@henlaw.com](mailto:Kirsten.Shultz@henlaw.com)>  
**Cc:** Lizzette Roman <[Lroman@fmbgov.com](mailto:Lroman@fmbgov.com)>  
**Subject:** RE: Special Magistrate Clerk

Kirsten,

I am technically the Clerk to the Special Magistrate for the Town, although my Lizzette Roman attends the hearings.

Is there something I can help you with? I have also copied Lizzette in the email.

Have a wonderful Christmas!

**Amy Baker**

*Town Clerk*

Town of Fort Myers Beach

6231 Estero Blvd

Fort Myers Beach, FL

33931

Phone: (239) 765-0202



**FMBgov.com**



As of January 1, 2024 the Town has implemented online records request. Please consider submitting your request through the portal. Any requests received via email will be transferred by staff to this portal, with all responses coming from "Town of Fort Myers Beach Public Records"

<https://fortmyersbeachfl.nextrequest.com/>

**From:** Kirsten Shultz <[Kirsten.Shultz@henlaw.com](mailto:Kirsten.Shultz@henlaw.com)>

**Sent:** Tuesday, December 23, 2025 3:38 PM

**To:** Amy Baker <[Amy@fmbgov.com](mailto:Amy@fmbgov.com)>

**Subject:** Special Magistrate Clerk

**CAUTION:** This email originated from outside of Town of Fort Myers Beach. Do not click links or open attachments unless you know the content is safe.

Good Afternoon: Sorry to bother you, but does the Special Magistrate Clerk have an email address? I have called 239-765-4222 and the mailbox is full. Thank you for any assistance.

**Kirsten Shultz**

Legal Assistant

Henderson, Franklin, Starnes & Holt, P.A.

1715 Monroe Street

Fort Myers, FL 33901

Direct Dial: 239.344.1208

Fax: 239.344.1208

[Kirsten.Shultz@henlaw.com](mailto:Kirsten.Shultz@henlaw.com)

[www.henlaw.com](http://www.henlaw.com)

Blogs: [www.swflbusinessandipblog.com](http://www.swflbusinessandipblog.com) • [www.legalscoopsfwflre.com](http://www.legalscoopsfwflre.com)



## CONFIDENTIALITY STATEMENT

Henderson, Franklin, Starnes & Holt, P.A.

The information contained in this transmission may contain privileged and confidential information. It is intended only for the us the person(s) named above. If you are not the intended recipient, you are hereby notified that any review, dissemination, distribu or duplication of this communication is strictly prohibited. If you are not the intended recipient, please contact the sender by repl mail and destroy all copies of the original message.

Note: Florida has a very broad public records law. Most communication(s) to or from Fort Myers Beach officials regarding Town business are public records available to the public and media upon request. Your email communications and email address may be subject to public disclosure.

Note: Florida has a very broad public records law. Most communication(s) to or from Fort Myers Beach officials regarding Town business are public records available to the public and media upon request. Your email communications and email address may be subject to public disclosure.

Note: Florida has a very broad public records law. Most communication(s) to or from Fort Myers Beach officials regarding Town business are public records available to the public and media upon request. Your email communications and email address may be subject to public disclosure.

# EXHIBIT A

- Notice of Violation & Hearing
- Evidence of Service
  - Affidavit of Positing
  - Evidence of Posting at violation address
  - Evidence of Posting at Town Hall
  - Evidence of Mailing / Certified Mail
- Evidence of Ownership
  - Lee County Property Appraisers
  - Tax Bill
- Initial Inspection Evidence
  - Photographs
  - Permit records
  - Other Evidence



Town of Fort Myers Beach

6231 Estero Blvd, Florida 33931
Phone: 239-765-0202 Fax: 239-765-0909

TOWN OF FORT MYERS BEACH,
FLORIDA,

Petitioner,
vs.

Table with 2 columns: Mail Type and Tracking/Postmark. Certified Mail: 9589071052713142134357, 9589071052703142134364. Regular Mail: USPS 11/12/2025

B+B Properties of Fort Myers LLC
Respondent.

AFFIDAVIT OF NOTICE AND POSTING

STATE OF FLORIDA
COUNTY OF LEE

BEFORE ME, the undersigned authority, personally appeared Michael J Hauserman, who being duly sworn by me, on oath, deposes and says the following regarding that certain Notice of Violation and Notice of Hearing attached hereto as Exhibit A ("the Notice"):

- 1. My name is Michael J Hauserman. I am over 18 years of age and am competent to testify to the matters set forth herein. I make this Affidavit based upon my personal knowledge.
2. I am employed as the Code Compliance Manager for the Town of Fort Myers Beach ("Town").
3. On 11/12/2025, I personally mailed a copy of the Notice by certified mail and first-class mail as follows:
a. To the property owner at the address listed in the records of the Lee County Tax Collector and/or Lee County Property Appraiser for tax notices, which address is: 21050 Saint Peters Drive, Fort Myers Beach, FL 33931. A true and correct copy of the property ownership and address information obtained from the Tax Collector/Property Appraiser is attached hereto as Exhibit A. A copy of the certified mail receipt is attached hereto as Exhibit A.

- b. [If applicable] To the following additional address(es) reasonably believed to be valid for the property owner: \_\_\_\_\_ . A copy of the certified mail receipt is attached hereto as **Exhibit A**.
- c. The property is owned by **B+B Properties of Fort Myers LLC**, a business entity registered in the State of Florida. I mailed a copy of the Notice by certified mail and first-class mail to the business entity's Registered Agent, **Gregory J Boyd, RA**, at the following address: 21050 Saint Peters Dr, Fort Myers Beach, FL 33931 . A copy of the certified mail receipt is attached hereto as **Exhibit A**. A true and correct copy of the Florida Division of Corporations record for the entity, identifying its Registered Agent, is attached hereto as **Exhibit A**.

4. On 11/12/2025, I posted a copy of the Notice at 1668 I Street, Fort Myers Beach, FL 33931, which is the property upon which the violation is alleged to exist. Photographs of the posted Notice, taken by me on that date, are attached hereto as **Exhibit A**.

5. On 11/12/2025, I posted a copy of the Notice at Town Hall, located at 6231 Estero Boulevard, Fort Myers Beach, FL 33931, which is the primary municipal government office for the Town of Fort Myers Beach. Photographs of the posted Notice, taken by me on that date, are attached hereto as **Exhibit A**.

Under penalties of perjury, I declare that I have read the foregoing Affidavit and that the facts stated in it are true and to the best of my knowledge and belief comply with Section 2-429 of the Town of Fort Myers Beach Land Development Code and Section 162.12, Florida Statutes.

**SWORN AND ATTESTED BY:**



Signature of Affiant

Printed Name: Michael J Hauserman

Title: Code Compliance Manager

The foregoing instrument was sworn to, subscribed and acknowledged before me by means of  physical presence /  online notarization, this 12<sup>th</sup> day of November, 2025 by Michael J Hauserman, who  is personally known to me  or has produced \_\_\_\_\_ as identification.



Notary Public, State of Florida

Printed Name: Ritleigh R Baker

My Commission No.: #H 637224

My Commission Expires: 2/5/2029



**Town of Fort Myers Beach**  
**NOTICE OF VIOLATION AND NOTICE OF CODE**  
**ENFORCEMENT HEARING**

6231 Estero Blvd, Fort Myers Beach, FL 33931

Phone: (239) 765-0202

Date: November 12, 2025

Case Number: **20250800**

Property Owner: B + B PROPERTIES OF FORT MYERS, LLC  
Mailing Address: 21050 Saint Peters Drive, Fort Myers Beach, FL 33931  
Subject Property Address: 1668 I Street, Fort Myers Beach, FL 33931  
Certified Mail# 9589071052703142134364, 9589071052703142134357  
Parcel: 19-46-24-W4-0070B.0110

YOU ARE HEREBY NOTIFIED that the undersigned Code Officer observed on November 10, 2025 the following violation(s) of the Land Development Code of the Town of Fort Myers Beach, Florida, were present on the subject property identified above:

**Code Violation:** On 11/10/2025, I observed multiple code violations including but not limited to lack of current valid building permit and building code deficiencies as defined in the Fort Myers Beach (FMB) Land Development Code Section 6-111, Florida Building Code (FBC) 105.1, and Section 6-441 of the FMB Land Development Code.

**CHAPTER 6 – MAINTENANCE CODES, BUILDING CODES AND COASTAL REGULATIONS**

**ARTICLE II. BUILDING CODES**

**DIVISION 3. – BUILDING CODE**

**SECTION 6-111. – Adoption; amendments.**

*The Florida Building Code is hereby adopted by reference and made a part of this article, including all revisions and amendments approved in accordance with state law, with the exceptions set forth as follows:*

**FBC 7<sup>th</sup> Edition Section 105 PERMITS 105.1 Required.**

*Any owner or owner's authorized agent who intends to construct, enlarge, alter, repair, move, demolish or change the occupancy of a building or structure, or to erect, install, enlarge, alter, repair, remove, convert or replace any impact-resistant coverings, electrical, gas, mechanical or plumbing system, the installation of which is regulated by this code, or to cause any such work to be performed, shall first make application to the building official and obtain the required permit.*

*FMB Sec. 6 - 441 Permits required Any owner or owner's authorized agent (hereinafter "applicant") who intends to undertake any development activity within the scope of this ordinance, including buildings, structures and facilities exempt from the Florida Building Code, which is wholly within or partially within any flood hazard area shall first make application to the Floodplain Administrator, and the Building Official if applicable, and shall obtain the required permit(s) and approval(s). No such permit or approval shall be issued until compliance with the requirements of the ordinance and all other applicable codes and regulations has been satisfied. No person may undertake a series of any improvements, additions, and/or demolitions that connect two or more existing structures in a manner that evades the requirements of this ordinance and the Florida Building Code.*

**Specific Violations:**

1. **FBC 7<sup>th</sup> Edition 1612.4 Design and construction. ASCE 24.7.1**  
**Violation:** Sink and associated plumbing located at ground level.  
**Corrective action:** The sink and associated plumbing will have to be removed from ground level or elevated to the required elevated location.
2. **FBC 7<sup>th</sup> Edition 1612.5 Floor hazard documentation.**  
**Violation:** Lack of V-Zone certificate provided with permit.  
**Corrective action:** Provide a V-Zone certificate to the Town with permit application.
3. **FBC 7<sup>th</sup> Edition 1612.4 Design and construction. ASCE 4.6.2**  
**Violation:** Lack of required hydrostatic relief vents. Blocked hydrostatic relief vents.  
**Corrective action:** Provide the required hydrostatic relief vents that are required per the FMB Floodplain Manager's comments. All hydrostatic relief vents must kept clear of blockage.
4. **FBC 7<sup>th</sup> Edition 1612.5 Flood hazard documentation.**  
**Violation:** Lack of required approved elevation certificate.  
**Corrective action:** Provide an approved elevation certificate for review and approved by the FMB Floodplain Manager.

**Corrective Action Required:** The following action is required to bring the violation(s) into compliance: Correct all deficiencies listed above as items 1-4. Obtain the required building permits once corrective action is taken for all unpermitted construction.

**Code Enforcement Compliance Date:** Compliance is required on or before **December 12, 2025**

If the referenced violations are corrected, you must contact the **Code Manager Michael J Hauserman at (239) 478-9363.**

**A HEARING FOR THIS MATTER HAS BEEN SCHEDULED FOR REVIEW BY THE SPECIAL MAGISTRATE ON THE 7th DAY OF JANUARY 2026, AT 9:00 AM, AT 6231 ESTERO BLVD, FORT MYERS BEACH, FL 33931. (Fort Myers Beach Town Hall Council Chambers)**

You are required to notify the undersigned Code Enforcement Officer when you complete the required actions to attain compliance with the Town's Codes. If you are able to complete the corrected action prior to the Code Enforcement Compliance Date, the scheduled hearing will be cancelled. Should all violations not be corrected and approved by the undersigned Code Enforcement Officer prior to the Code Enforcement Compliance Date, you will be required to appear at the scheduled hearing before the Town's Special Magistrate, pursuant to Division 2 of Article V of Chapter 2 of the Town Land Development Code and Chapter 162, Florida Statutes. If a violation is corrected after the Code Enforcement Compliance Date but before the scheduled hearing, the case may still be presented to the Special Magistrate.

The Code Officer has reason to believe that the violation(s) or the condition causing the violation(s) presents a serious threat to the public health, safety, and welfare or is irreparable or irreversible in nature. Therefore, no Code Enforcement Compliance Date has been provided, and the case may be presented to the Special Magistrate even if the violation(s) have been corrected prior to the hearing.

The Code Officer has reason to believe that this violation is the same violation that occurred within the past 5 years ("Repeat Violation"). Therefore, no Code Enforcement Compliance Date has been provided. This case may be presented to the Special Magistrate even if the Repeat Violation(s) have been corrected prior to the hearing.

The purpose of the scheduled Code Enforcement Hearing is for the Special Magistrate to make "Findings of Fact" and "Conclusions of Law" relating to the observed violation(s) and to issue an appropriate Order. The Hearing is also your opportunity to present evidence and/or contest the observed violations, should you wish to do so. If a violation is found, the Order may require you to correct the violation(s) by a specified date. In addition, the Order may impose daily fines as per Florida Statutes Section 162.09(2)(a) of the following:

- \$250/ day per violation
- \$500/day for repeat offenses
- \$5,000 for irreversible or irreparable violations

Additionally, administrative fees may be requested by the Town to recover all costs incurred by the Town in scheduling and presenting the code enforcement case to the Special Magistrate as ordered by the Special Magistrate. **THE IMPOSITION OF FINES AND/OR ADMINISTRATIVE FEES AND COSTS MAY RESULT IN A FUTURE LIEN AGAINST YOUR PERSONAL AND REAL PROPERTY.**

You have the right to be represented by an attorney at the scheduled hearing and to respond and present evidence (documents and testimony by witnesses) at the scheduled hearing. If you wish to be represented by an attorney, your attorney **MUST** notify the Special Magistrate's Clerk in writing at least five (5) working days before the scheduled hearing.

You may also have other rights which are set forth in Division 2 of Article V of Chapter 2 of the Town Land Development Code. If a person decides to appeal any decision with respect to any matter considered at the scheduled hearing, such person will need to ensure that a verbatim record of the proceedings is made, which includes the testimony and evidence upon which the appeal is to be based (Section 286.0105, Florida Statutes).

For additional information, contact the Town of Fort Myers Beach Special Magistrate Clerk at (239) 765-4222.

Michael J Hauserman



---

Code Enforcement Manager  
Fort Myers Beach, Florida  
239-478-9363



Nov 12, 2025 2:14:54 PM  
Fort Myers Beach

garbage.

**Corrective Action Required:**

The following actions are required to bring the violation(s) into compliance. (1) Cut/Mow weeds and grass and maintain the property free from weeds or plant growth in excess of 12 inches. (2) remove or replace the tarp on the roof so it no longer creates litter. (3) repair the building so loose objects, such as railings, can fall or blow onto other properties in a high wind event. Replacement will require permits. Questions call Permitting at 239-765-0202.

Upon failure of the owner or agent having charge of a property to cut and destroy weeds after service of a notice of violation and having been given a reasonable time to cut and destroy the

11-12-25  
M



**Town of Fort Myers Beach**  
**NOTICE OF VIOLATION AND NOTICE OF CODE**  
**ENFORCEMENT HEARING**  
6231 Estero Blvd, Fort Myers Beach, FL 33931  
Phone: (239) 765-0202

Date: November 12, 2025

Case Number: 20250800

Property Owner: B + B PROPERTIES OF FORT MYERS, LLC  
Mailing Address: 21050 Saint Peters Drive, Fort Myers Beach, FL 33931  
Subject Property Address: 1668 I Street, Fort Myers Beach, FL 33931  
Certified Mail# 9589071052703142134364, 9589071052703142134357  
Parcel: 19-46-24-W4-0070B.0110

YOU ARE HEREBY NOTIFIED that the undersigned Code Officer observed on November 10, 2025 the following violation(s) of the Land Development Code of the Town of Fort Myers Beach, Florida, were present on the subject property identified above.

**Code Violation:** On 11/10/2025, I observed multiple code violations including but not limited to lack of current valid building permit and building code deficiencies as defined in the Fort Myers Beach (FMB) Land Development Code Section 6-111, Florida Building Code (FBC) 105.1, and Section 6-411 of the FMB Land Development Code.

**CHAPTER 6 - MAINTENANCE CODES, BUILDING CODES AND COASTAL REGULATIONS**  
**ARTICLE 11. BUILDING CODES**  
**DIVISION 3. - BUILDING CODE**  
**SECTION 6-111. - Adoption; amendments.**

The Florida Building Code is hereby adopted by reference and made a part of this article, including all revisions and amendments approved in accordance with state law, with the exceptions set forth as follows:

**FBC 7th Edition Section 105 PERMITS 105.1 Required.**  
Any owner or owner's authorized agent who intends to construct, enlarge, alter, repair, move, demolish or change the occupancy of a building or structure, or to erect, install, enlarge, alter, repair, move, demolish or change impact-resistant coverings, electrical, gas, mechanical or plumbing system, the installation of which is regulated by this code, or to cause any such work to be performed, shall first make application to the building official and obtain the required permit.

**FMB Sec. 6 - 411 Permits required.** Any owner or owner's authorized agent (hereinafter "applicant") who intends to undertake any development activity within the scope of this ordinance, including buildings, structures and facilities exempt from the Florida Building Code, which is wholly within or partially within any flood hazard area shall first make application to the Building Official and the Building Official, if applicable, and shall obtain the required permit(s) and approval(s). No such permit or approval shall be issued until the applicant has first undertaken a review of any improvements, additions, and/or demolitions that connect two or more existing structures in a manner that violates the requirements of this ordinance and the Florida Building Code.

Nov 12, 2025 2:14:51 PM  
Fort Myers Beach



**Town of Fort Myers Beach**  
**NOTICE OF VIOLATION AND NOTICE OF CODE**  
**ENFORCEMENT HEARING**  
 6231 Estero Blvd, Fort Myers Beach, FL 33931  
 Phone: (239) 765-0202

*MT*

Date: November 12, 2025

Case Number: 20250800

Property Owner: B + B PROPERTIES OF FORT MYERS, LLC  
 Mailing Address: 21050 Saint Peters Drive, Fort Myers Beach, FL 33931  
 Subject Property Address: 1668 I Street, Fort Myers Beach, FL 33931  
 Certified Mail#: 9559071052703142134364, 9589071052703142134357  
 Parcel: 19-46-24-W4-0700.0110

YOU ARE HEREBY NOTIFIED that the undersigned Code Officer observed on November 10, 2025 the following violator(s) of the Land Development Code of the Town of Fort Myers Beach, Florida, were present on the subject property identified above:

**Code Violation:** On 11/10/2025, I observed multiple code violations including but not limited to lack of current valid building permit and building code deficiencies as defined in the Fort Myers Beach (FMB) Land Development Code Section 6-111, Florida Building Code (FBC) 105.1, and Section 6-441 of the FMB Land Development Code.

**CHAPTER 6 - MAINTENANCE CODES, BUILDING CODES AND COASTAL REGULATIONS**  
**ARTICLE 11 - BUILDING CODES**  
**SECTION 6-111 - BUILDING CODE**  
**DIVISION 3 - BUILDING CODE**  
**SECTION 6-111 - Adoption; an amendment.**  
*The Florida Building Code is hereby adopted by reference and made a part of this article, including all revisions and amendments approved in accordance with state law, with the exceptions set forth as follows:*

**FBC 7<sup>th</sup> Edition Section 105 PERMITS 105.1 Required.**  
*Any owner or owner's authorized agent who intends to construct, enlarge, alter, repair, move, demolish or change the occupancy of a building or structure, or to erect, install, enlarge, alter, repair, remove, convert or replace any impact-resistant covering, electrical, gas, mechanical or plumbing system, the installation of which is regulated by this code, or to cause any such work to be performed, shall first make application to the building official and obtain the required permit.*

**FMB Sec. 6 - 41 Permit required.** *Any owner or owner's authorized agent (hereinafter "applicant") who intends to undertake any development activity within the scope of this ordinance, including building, repairs and facilities exempt from the Florida Building Code, which is wholly, wholly or partially within any flood hazard area shall first make application to the Floodplain Administrator, and the Building Official if applicable, and shall obtain the required permit(s) and approval(s). No such permit or approval shall be issued until compliance with the requirements of the ordinance and all other applicable codes and regulations has been satisfied. No person may undertake a series of any improvements, additions, and/or demolitions that connect two or more existing structures in a manner that violates the requirements of this ordinance and the Florida Building Code.*

Page 1 of 3

Nov 12, 2025 2:47:30 PM  
 Fort Myers Beach



Nov 12, 2025 2:47:43 PM  
Fort Myers Beach



9589 0710 5270 3142 1343 57

U.S. Postal Service™ **20250800**  
**CERTIFIED MAIL® RECEIPT**  
*Domestic Mail Only*

For delivery information, visit our website at [www.usps.com](http://www.usps.com).

**OFFICIAL USE**

Certified Mail Fee	\$
Extra Services & Fees (check box, add fee as appropriate)	
<input type="checkbox"/> Return Receipt (hardcopy)	\$
<input type="checkbox"/> Return Receipt (electronic)	\$
<input type="checkbox"/> Certified Mail Restricted Delivery	\$
<input type="checkbox"/> Adult Signature Required	\$
<input type="checkbox"/> Adult Signature Restricted Delivery	\$
Postage	\$
Total Postage and Fees	\$

Postmark  
*MM*

Sent To: B+B PROPERTIES OF FORT MYERS, LLC  
 Street: C/O Gregory J Boyd, RA  
 City, St: 21050 Saint Peters Drive  
 Fort Myers Beach, FL 333931

PS Form 3800, January 2023 PSN 7530-02-000-9047 See Reverse for Instructions

9589 0710 5270 3142 1343 64

U.S. Postal Service™ **20250800**  
**CERTIFIED MAIL® RECEIPT**  
*Domestic Mail Only*

For delivery information, visit our website at [www.usps.com](http://www.usps.com).

**OFFICIAL USE**

Certified Mail Fee	\$
Extra Services & Fees (check box, add fee as appropriate)	
<input type="checkbox"/> Return Receipt (hardcopy)	\$
<input type="checkbox"/> Return Receipt (electronic)	\$
<input type="checkbox"/> Certified Mail Restricted Delivery	\$
<input type="checkbox"/> Adult Signature Required	\$
<input type="checkbox"/> Adult Signature Restricted Delivery	\$
Postage	\$
Total Postage and Fees	\$

Postmark  
*MM*

Sent To: B+B PROPERTIES OF FORT MYERS, LLC  
 Street: 21050 Saint Peters Drive  
 City, St: Fort Myers Beach, FL 333931

PS Form 3800, January 2023 PSN 7530-02-000-9047 See Reverse for Instructions



# Property Data

STRAP: 19-46-24-W4-0070B.0110 Folio ID: 10228182

Tax Roll Value Letter 2025 ▾

Generated on 11/10/2025 12:00 PM

### Owner Of Record - Sole Owner [\[Change Mailing Address\]](#)



B + B PROPERTIES OF FORT MYERS  
21050 SAINT PETERS DR  
FORT MYERS BEACH FL 33931

### Site Address

Site Address maintained by [E911 Program Addressing](#)

1668 I ST  
FORT MYERS BEACH FL 33931

### Property Description

Do not use for legal documents!



CRESCENT BEACH BLK.B PB 4 PG 45 LOT 11

[View Recorded Plat at LeeClerk.org](#) - Use this link to do an Official Records search on the Lee County Clerk of Courts website, using 4 and 45 for the book and page numbers.

#### Attributes and Location Details

Total Bedrooms / Bathrooms	4 / 4.0
1st Year Building on Tax Roll	2025
Historic Designation	No

Township	Range	Section	Block	Lot
46	24E	19	0070B	0110
Municipality	Latitude	Longitude		
Town of Fort Myers Beach	26.45019	-81.94948		

[View Parcel on Google Maps](#)

### [ Tax Map Viewer ] [ View Comparables ]



### [ Pictometry Aerial Viewer ]

### Image of Structure



◀ Photo Date July of 2025 ▶  View other photos

Last Inspection Date: 01/22/2025

## Property Values / Exemptions / TRIM Notices

Generated on 11/10/2025 12:00 PM

No existing exemptions found for this property.

TRIM Notices	Tax Year	Just	Land	Market Assessed	Capped Assessed	Exemptions	Classified Use	Taxable
<a href="#">2025 / Additional Info</a>	2025 (Final Value)	2,228,905	2,228,905	2,228,905	1,208,788	0	0	1,208,788
<a href="#">2024 / Additional Info</a>	2024 (Final Value)	2,228,905	2,228,905	2,228,905	1,098,898	0	0	1,098,898
<a href="#">2023 / Additional Info</a>	2023 (Final Value)	1,639,334	1,639,334	1,639,334	998,998	0	0	998,998

**Building 1 of 1**

**Building Characteristics**

<b>Improvement Type</b>	<b>Model Type</b>	<b>Stories</b>	<b>Living Units</b>
21 - Stores/Office/Res Combination	4 - COMMERCIAL	3.0	2
<b>Bedrooms</b>	<b>Fixtures</b>	<b>Year Built</b>	<b>Effective Year Built</b>
4	4.0	2025	2025

**Building Subareas**

<b>Description</b>	<b>Heated / Under Air</b>	<b>Area (Sq Ft)</b>
AP2 - APARTMENT 2	Y	1,325
APT - APARTMENT	Y	1,858
BAL - BALCONY	N	63
BAS - BASE	Y	281
FCP - FINISHED CARPORT	N	1,577
FEP - FINISHED ENCLOSED PORCH	N	63
FOP - FINISHED OPEN PORCH	N	320
FOP - FINISHED OPEN PORCH	N	320
FOP - FINISHED OPEN PORCH	N	320

**Building Features**

<b>Description</b>	<b>Year Added</b>	<b>Units</b>
ELEVATOR - FREIGHT	2025	3
SPRINKLER SYSTEM (INTERIOR)	2025	6,224

**Building Front Photo**



**Photo Date: July of 2025**

**Building Footprint**

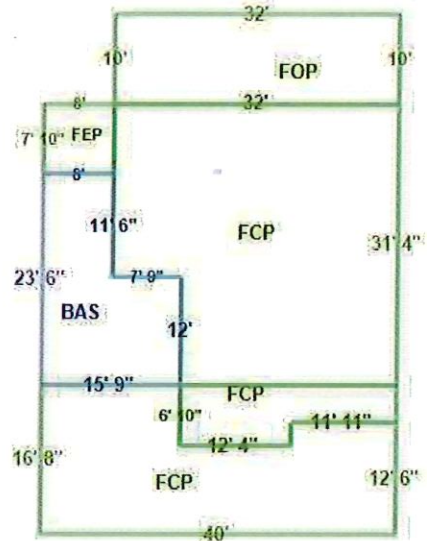

Description	Heated / Under Air	Area (Sq Ft)
AP2 - APARTMENT 2	Y	1,325
APT - APARTMENT	Y	1,858
BAL - BALCONY	N	63
BAS - BASE	Y	281
FEP - FINISHED ENCLOSED PORCH	N	973
FGR - FINISHED GARAGE	N	667
FOP - FINISHED OPEN PORCH	N	320
FOP - FINISHED OPEN PORCH	N	320
FOP - FINISHED OPEN PORCH	N	320

**Building Features**

Description	Year Added	Units
ELEVATOR - FREIGHT	2025	3
SPRINKLER SYSTEM (INTERIOR)	2025	6,224

**Building Front Photo**



Photo Date: July of 2025

**Building Footprint**

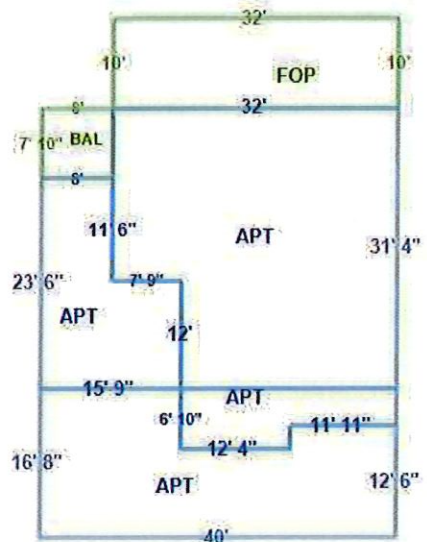
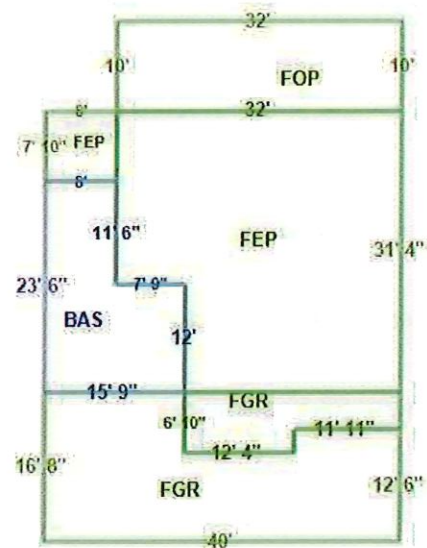

### Sales / Transactions

Generated on 11/10/2025 12:01 PM

Sale Price	Date	Clerk File Number	Type	Notes	Vacant/Improved
800,000.00	12/04/2009	2009000330729	01		I
1,700,000.00	03/24/2005	4643/2138	08		I
100.00	04/22/2004	4308/654	01		I
192,000.00	11/01/1987	1952/218	06		I
83,500.00	04/01/1977	1196/980	06		I

[View Recorded Plat at LeeClerk.org](#)

Use the above link to do a search on the Lee County Clerk of Courts website, using **4** and **45** for the book and page numbers and **Plats Book** for the book type.

Help safeguard your home against property fraud. Sign up for the Lee Clerk's free [Property Fraud Alert](#).

### Building / Construction Permit Data

Generated on 11/10/2025 12:01 PM

Permit Number	Permit Type	Date
240836	Building New Construction	10/30/2024
242556	Fence	10/16/2024
224382	Mobile Home	07/31/2023
234424	Demolition	07/10/2023
224847	Site Development - Driveway / Sidewalks	02/03/2023
225045	Electric	12/22/2022
ROF17-0029	Roof	04/07/2017
ELE15-0153	Electric	06/01/2015
COM15-0173	Shutter, Awning	05/29/2015
FIR13-0041	Fire	09/06/2013
COM10-0123	Building Remodel / Repair	08/09/2010
FNC2007-00944	Fence	05/14/2007
COM2005-01361	Building Remodel / Repair	07/12/2005
ROF2004-08413	Roof	12/17/2004
198911388	Commercial	10/23/1989

**IMPORTANT: THIS MAY NOT BE A COMPREHENSIVE OR TIMELY LISTING OF PERMITS ISSUED FOR THIS PROPERTY.**

Note: The Lee County Property Appraiser's Office does not issue or maintain any permit information. The Building / Construction permit data displayed here represents only those records this Office may find necessary to conduct Property Appraiser business. Use of this information is with the understanding that in no way is this to be considered a comprehensive listing of permits for this or any other parcel.

The Date field represents the date the property appraiser received information regarding permit activity; it may or not represent the actual date of permit

**DO NOT PAY - THIS IS NOT A BILL**  
**NOTICE OF PROPOSED PROPERTY TAXES**  
**TAX INFORMATION**

10228182  
 B + B PROPERTIES OF FORT MYERS  
 21050 SAINT PETERS DR  
 FORT MYERS BEACH, FL 33931

532014  
 Parcel ID: 19-46-24-W4-0070B.0110  
 CRESCENT BEACH  
 BLK.B PB 4 PG 45  
 LOT 11  
 1668 I ST

The taxing authorities which levy property taxes against your property will soon hold PUBLIC HEARINGS to adopt budgets and tax rates for the next year.

The purpose of these PUBLIC HEARINGS is to receive opinions from the general public and to answer questions on the proposed tax change and budget PRIOR TO TAKING FINAL ACTION. Each taxing authority may AMEND OR ALTER its proposals at the hearing.

TAXING AUTHORITY ⓘ		COLUMN 1*		COLUMN 2*		COLUMN 3*
277 TOWN OF FM BCH / FM BCH DOWNTOWN REDEV	LAST YEAR'S ACTUAL TAX RATE 2024 (MILLAGE) ⓘ	YOUR PROPERTY TAXES LAST YEAR 2024	YOUR TAX RATE THIS YEAR IF NO BUDGET CHANGE IS ADOPTED (MILLAGE)	YOUR TAXES THIS YEAR IF NO BUDGET CHANGE IS ADOPTED	THIS YEAR'S PROPOSED TAX RATE 2025 (MILLAGE)	YOUR TAXES IF PROPOSED BUDGET CHANGE IS ADOPTED 2025
<b>COUNTY:</b>						
LEE CO GENERAL REVENUE	3.7623	\$4,134.38	3.6162	\$4,371.22	3.7623	\$4,547.82
<b>SCHOOL:</b>						
PUBLIC SCHOOL - BY LOCAL BOARD	2.2480	\$5,010.58	2.2302	\$4,970.90	2.2480	\$5,010.58
PUBLIC SCHOOL - BY STATE LAW	3.0380	\$6,771.41	3.0139	\$6,717.70	3.0710	\$6,844.97
<b>MUNICIPALITY OR MSTU:</b>						
TOWN OF FORT MYERS BEACH FLORIDA	0.9900	\$1,087.91	0.8954	\$1,082.35	1.2550	\$1,517.03
<b>WATER MANAGEMENT DISTRICT:</b>						
SFWM-DISTRICT-WIDE	0.0948	\$104.18	0.0889	\$107.46	0.0948	\$114.59
SFWM-EVERGLADES CONSTRUCTION PROJECT	0.0327	\$35.93	0.0306	\$36.99	0.0327	\$39.53
SFWM-OKEECHOBEE BASIN	0.1026	\$112.75	0.0961	\$116.16	0.1026	\$124.02
<b>INDEPENDENT SPECIAL DISTRICTS:</b>						
FORT MYERS BEACH FIRE CONTROL DIST	2.8000	\$3,076.91	2.5436	\$3,074.67	2.8000	\$3,384.61
FORT MYERS BEACH MOSQUITO CONTROL	0.1123	\$123.41	0.1018	\$123.05	0.1123	\$135.75
FORT MYERS BEACH PUBLIC LIBRARY DIST	0.1612	\$177.14	0.1464	\$176.97	0.1612	\$194.86
LEE CO HYACINTH CONTROL DIST	0.0200	\$21.98	0.0192	\$23.21	0.0200	\$24.18
WEST COAST INLAND NAVIGATION DIST	0.0394	\$43.30	0.0381	\$46.05	0.0394	\$47.63
<b>TOTAL TAX RATES:</b>	13.4013		12.8204		13.6993	
<b>TOTAL PROPERTY TAXES:</b>		\$20,699.88		\$20,846.73		\$21,985.57
		<b>COLUMN 1*</b>		<b>COLUMN 2*</b>		<b>COLUMN 3*</b>

**NOTICE OF PROPOSED PROPERTY TAXES EXPLANATION (Section 200.069, Florida Statutes)**

\***COLUMN 1**—"YOUR PROPERTY TAXES LAST YEAR" - This column shows the taxes that applied last year to your property. These amounts were based on budgets adopted last year and your property's previous taxable value.

\***COLUMN 2**—"YOUR TAXES IF NO BUDGET CHANGE IS ADOPTED" - This column shows what your taxes will be this year IF EACH TAXING AUTHORITY DOES NOT CHANGE ITS PROPERTY TAX LEVY. These amounts are based on last year's budgets and your current assessment.

\***COLUMN 3**—"YOUR TAXES IF PROPOSED BUDGET CHANGE IS ADOPTED" - This column shows what your taxes will be this year under the BUDGET ACTUALLY PROPOSED by each local taxing authority. The proposal is NOT final and may be amended at the public hearings shown on this notice. The difference between Columns 2 and 3 is the tax change proposed by each local taxing authority and is NOT the result of higher assessments.

**NOTE:** Amounts shown on this form do NOT reflect early payment discounts you may have received or may be eligible to receive. (Discounts are a maximum of 4 percent of the amounts shown on this form.)

**NON-AD VALOREM ASSESSMENTS:** ⓘ Your final tax bill may contain non-ad valorem assessments which may not be reflected on this notice such as assessments for roads, fire, garbage, lighting, drainage, water, sewer, or other governmental services and facilities which may be levied by your county, city, or any special district

**A Public Hearing ⓘ on the Proposed Taxes and Budget Will Be Held:**

COUNTY/MSTU:	09/04/2025 5:05PM	Lee Co Commission Chambers	2120 Main St	Fort Myers FL 33901	239-533-2221
SCHOOL:	09/09/2025 5:05PM		2855 Colonial Blvd	Fort Myers FL 33966	239-337-8215
MUNICIPALITY:	09/11/2025 5:01PM		6231 Estero Blvd	Fort Myers Beach FL 33931	239-765-0202
WATER MANAGEMENT DISTRICT:	09/11/2025 5:15PM	SFWM Auditorium	3301 Gun Club Rd B-1 Bldg	West Palm Beach FL 33406	561-686-8800
LEE CO MOSQUITO AND/OR HYACINTH:	09/11/2025 5:01PM/5:15PM		15191 Homestead Rd	Lehigh Acres FL 33971	239-694-2174
FORT MYERS BEACH FIRE CONTROL DIST:	09/10/2025 5:05PM	Diamond Head Resort	2000 Estero Blvd	Ft Myers Beach FL 33931	239-590-4200
FORT MYERS BEACH MOSQUITO CONTROL:	09/03/2025 5:01PM		161 Bay Rd	Ft Myers Beach FL 33931	239-247-1205
FORT MYERS BEACH PUBLIC LIBRARY DIST:	09/11/2025 5:05PM		2755 Estero Blvd	Ft Myers Beach FL 33931	239-463-9691
WEST COAST INLAND NAVIGATION DISTRICT:	09/05/2025 5:01PM		1575 E Venice Ave	Venice FL 34292	941-485-9402

\*\* PROPERTY RECORD UPDATE -- WEBSITE AND PERSONALIZED CODE FOR 2025\*\*

Enter your [personalized code TR9C11D6](#) to review your property details and

- Report or update hurricane damage

PROPERTY VALUATION		
	Last Year 2024 ⓘ	This Year 2025 ⓘ
<b>MARKET VALUE</b>	<b>\$2,228,905</b>	<b>\$2,228,905</b>
<b>Market Value</b> in Florida is also known as "just value" as provided by the constitution and described in state law. It is the amount a purchaser willing but not obliged to buy would pay to one willing but not obliged to sell, after proper consideration of all eight factors in section 193.011, F.S.		
<b>ASSESSED VALUE</b>		
<b>Assessed Value</b> is the market value of your property minus the amount of any assessment reductions. The assessed value may be different for millage levies made by different taxing authorities.		
<b>ASSESSMENT REDUCTIONS</b>	<b>APPLIES TO</b>	<b>VALUE</b>
<b>Assessment Reduction</b> amounts are based on applicable statutory limitations and benefits that may affect the Assessed Value, such as the Save Our Homes cap or an Agricultural Classification. The value of these limitations and benefits make up the difference between market and assessed value.		
Assessment Limitation Benefit	Non-School Levies	\$1,020,117
<b>EXEMPTIONS</b>	<b>APPLIES TO</b>	<b>VALUE</b>
<b>Exemptions</b> are specific dollar or percentage amounts that reduce taxable value. These are usually based on characteristics of the property or property owner. Examples include the homestead exemption, veterans' disability exemptions and charitable exemptions. In some cases, the maximum exemption amount may not be applied because of a lower assessed value. Many exemptions apply only to tax levies by the taxing authority granting the exemption.		

VALUE CALCULATIONS						
<b>Taxable Value</b> is the assessed value minus qualifying exemptions. This is the value used to calculate the tax due on your property. The assessed and taxable values may vary by taxing authority because certain assessment reductions and exemptions may not apply to all levies and discounts.						
TAXING AUTHORITY	ASSESSED VALUE		EXEMPTIONS		TAXABLE VALUE	
	LAST YEAR	THIS YEAR	LAST YEAR	THIS YEAR	LAST YEAR	THIS YEAR ⓘ
<b>COUNTY:</b>						
LEE CO GENERAL REVENUE	\$1,098,898	\$1,208,788	\$0	\$0	\$1,098,898	\$1,208,788
<b>SCHOOL:</b>						
PUBLIC SCHOOL - BY LOCAL BOARD	\$2,228,905	\$2,228,905	\$0	\$0	\$2,228,905	\$2,228,905
PUBLIC SCHOOL - BY STATE LAW	\$2,228,905	\$2,228,905	\$0	\$0	\$2,228,905	\$2,228,905
<b>MUNICIPALITY OR MSTU:</b>						
TOWN OF FORT MYERS BEACH FLORIDA	\$1,098,898	\$1,208,788	\$0	\$0	\$1,098,898	\$1,208,788
<b>WATER MANAGEMENT DISTRICT:</b>						
SFWMD-DISTRICT-WIDE	\$1,098,898	\$1,208,788	\$0	\$0	\$1,098,898	\$1,208,788
SFWMD-EVERGLADES CONSTRUCTION PROJECT	\$1,098,898	\$1,208,788	\$0	\$0	\$1,098,898	\$1,208,788
SFWMD-OKEECHOBEE BASIN	\$1,098,898	\$1,208,788	\$0	\$0	\$1,098,898	\$1,208,788
<b>INDEPENDENT SPECIAL DISTRICTS:</b>						
FORT MYERS BEACH FIRE CONTROL DIST	\$1,098,898	\$1,208,788	\$0	\$0	\$1,098,898	\$1,208,788
FORT MYERS BEACH MOSQUITO CONTROL	\$1,098,898	\$1,208,788	\$0	\$0	\$1,098,898	\$1,208,788
FORT MYERS BEACH PUBLIC LIBRARY DIST	\$1,098,898	\$1,208,788	\$0	\$0	\$1,098,898	\$1,208,788
LEE CO HYACINTH CONTROL DIST	\$1,098,898	\$1,208,788	\$0	\$0	\$1,098,898	\$1,208,788
WEST COAST INLAND NAVIGATION DIST	\$1,098,898	\$1,208,788	\$0	\$0	\$1,098,898	\$1,208,788

If you feel the market value of your property is inaccurate or does not reflect fair market value, or if you are entitled to an exemption or classification that is not reflected on this form, please call us at (239) 533-6100 or visit the Lee County Property Appraiser's office at 2480 Thompson Street, 4th Floor, Fort Myers, FL.

If we are unable to resolve a matter as to the market value, classification, or an exemption, you may file a petition for adjustment with the Value Adjustment Board. ⓘ Online filing is available at [www.leeclerk.org](http://www.leeclerk.org). Petition forms are available from the Lee County Property Appraiser's office. All petitions must be filed with the Clerk of Courts Office on or before **September 12, 2025**.

**\*\* PROPERTY RECORD UPDATE -- WEBSITE AND PERSONALIZED CODE FOR 2025\*\***

Enter your [personalized code TR9C11D6](#) to review your property details and

- Report or update hurricane damage
- Confirm or update your homestead exemption status
- Discover how your value was impacted

Prepared by and Return Recorded Original to:

Charles R. Meador, Jr., Attorney at Law  
2085 Estero Boulevard  
Fort Myers Beach, FL 33931  
Telephone: (239) 463-6619  
Facsimile: (239) 463-6454

Property Appraiser Parcel I.D. No. 19-46-24-W4-0070B.0110  
Grantee Taxpayer I.D. No. \_\_\_\_\_  
Documentary Stamp Tax on Transfer: \$5600



Reserved For Recorder

(STATUTORY FORM - Section 689.02, F.S.)

**WARRANTY DEED**

THIS WARRANTY DEED, made this 4 day of DECEMBER, A.D. 2009, between LAKESIDE PROPERTIES, LLC, a Florida limited liability company, whose post office address is P.O. Box 1, Branch 1, Fort Myers Beach, FL 33931, hereinafter called Grantor, and B+B PROPERTIES OF FORT MYERS BEACH, LLC, a Florida limited liability company, whose post office address is 21050 St. Peters Drive, Fort Myers Beach, FL 33931, hereinafter called Grantee.

WITNESSETH, That said Grantor, for and in consideration of the sum of Ten and No/100's Dollars (\$10.00), and other good and valuable consideration, to said Grantor in hand paid by said Grantee, the receipt whereof is hereby acknowledged, has granted, bargained, and sold to the said Grantee, and Grantee's heirs and assigns forever, the following described land, situate, lying and being in Lee County, Florida, to-wit:

Lot 11, Block B, CRESCENT BEACH SUBDIVISION, according to the map or plat thereof on file and recorded in the office of the Clerk of the Circuit Court in Plat Book 4, Page 45, Public Records of Lee County, Florida.

SUBJECT TO easements, restrictions and reservations of record and taxes for the current and subsequent years.

and said Grantor does hereby fully warrant the title to said land, and will defend the same against lawful claims of all persons whomsoever.

\*"Grantor" and "Grantee" are used for singular and plural, as context requires.

IN WITNESS WHEREOF, Grantor has hereunto set Grantor's hand and seal the day and



Reserved For Recorder

year first above written.

Signed in the presence of:

LAKESIDE PROPERTIES, LLC, a Florida limited liability company

By: CHEMONG ENTERPRISES, LLC, a Nevis limited liability company, as Manager

WI

x M. Bea  
✓ M. Bea  
Witness Name - print or type

By: x Alida Carlsake  
Alida Carlsake, as Manager

WII

x Nancy Day  
✓ NANCY DAY  
Witness Name - print or type

PROVINCE

~~STATE~~ OF ONTARIO  
COUNTY OF PETERBOROUGH, CANADA

EXECUTION OF the foregoing instrument was acknowledged before me this 4 day of DECEMBER, 2009, by Alida Carlsake, as Manager of CHEMONG ENTERPRISES, LLC, a Nevis limited liability company, as Manager of LAKESIDE PROPERTIES, LLC, a Florida limited liability company, who is (CHECK ONE OF THE FOLLOWING AS APPLICABLE) [] personally known to me, or [ ] who has produced ( ) as identification.

x John Joseph Crook  
NOTARY PUBLIC - SIGNATURE ABOVE

NOTARY NAME - JOHN JOSEPH CROOK (Notary Seal)  
COMMISSION NO. - N/A  
COMMISSION EXP. DATE - LIFE  
(Notary Name/Commission No./Exp. Date - typed or printed)



[Department of State](#) / [Division of Corporations](#) / [Search Records](#) / [Search by Entity Name](#) /

## Detail by Entity Name

Florida Limited Liability Company

B + B PROPERTIES OF FORT MYERS BEACH, LLC

### Filing Information

**Document Number** L09000115105  
**FEI/EIN Number** 27-1417918  
**Date Filed** 12/02/2009  
**State** FL  
**Status** ACTIVE

### Principal Address

21050 ST PETERS DR  
 FT MYERS BEACH, FL 33931

### Mailing Address

21050 ST PETERS DR  
 FT MYERS BEACH, FL 33931

### Registered Agent Name & Address

BOYD, GREGORY J  
 21050 ST. PETER'S DR  
 FT MYERS BEACH, FL 33931

Name Changed: 02/11/2012

Address Changed: 02/11/2012

### Authorized Person(s) Detail

#### **Name & Address**

Title MGR

BOYD, GREGORY J  
 21050 ST PETERS DR  
 FT MYERS BEACH, FL 33931

Title MGR

BOYD, MADELINE M  
 604 HUDSON STREET #2  
 HOBOKEN, NJ 07030

## **Annual Reports**

<b>Report Year</b>	<b>Filed Date</b>
2023	02/14/2023
2024	02/29/2024
2025	02/13/2025

## **Document Images**

<a href="#">02/13/2025 -- ANNUAL REPORT</a>	<a href="#">View image in PDF format</a>
<a href="#">02/29/2024 -- ANNUAL REPORT</a>	<a href="#">View image in PDF format</a>
<a href="#">02/14/2023 -- ANNUAL REPORT</a>	<a href="#">View image in PDF format</a>
<a href="#">02/24/2022 -- ANNUAL REPORT</a>	<a href="#">View image in PDF format</a>
<a href="#">01/21/2021 -- ANNUAL REPORT</a>	<a href="#">View image in PDF format</a>
<a href="#">01/27/2020 -- ANNUAL REPORT</a>	<a href="#">View image in PDF format</a>
<a href="#">02/05/2019 -- ANNUAL REPORT</a>	<a href="#">View image in PDF format</a>
<a href="#">01/15/2018 -- ANNUAL REPORT</a>	<a href="#">View image in PDF format</a>
<a href="#">02/07/2017 -- ANNUAL REPORT</a>	<a href="#">View image in PDF format</a>
<a href="#">02/17/2016 -- ANNUAL REPORT</a>	<a href="#">View image in PDF format</a>
<a href="#">02/23/2015 -- ANNUAL REPORT</a>	<a href="#">View image in PDF format</a>
<a href="#">02/28/2014 -- ANNUAL REPORT</a>	<a href="#">View image in PDF format</a>
<a href="#">02/20/2013 -- ANNUAL REPORT</a>	<a href="#">View image in PDF format</a>
<a href="#">02/11/2012 -- ANNUAL REPORT</a>	<a href="#">View image in PDF format</a>
<a href="#">02/11/2011 -- ANNUAL REPORT</a>	<a href="#">View image in PDF format</a>
<a href="#">03/04/2010 -- ANNUAL REPORT</a>	<a href="#">View image in PDF format</a>
<a href="#">12/02/2009 -- Florida Limited Liability</a>	<a href="#">View image in PDF format</a>



Subject: Revocation of Permit Due to Non-Compliance with Floodplain Requirements in AE Flood Zone

Dear B + B PROPERTIES OF FORT MYERS,

This letter serves as formal notice that the Town of Fort Myers Beach is revoking the building permit previously issued for your property located at **1668 I St Fort Myers Beach, FL 33931**. (STRAP# 194624W40070B0110)

Upon further review, it has been determined that the permit was issued in error. The proposed development is located within a FEMA-designated AE Flood Zone and does not currently meet the floodplain management requirements established by FEMA and adopted by the Town.

Reason for Revocation:

As a participant in the National Flood Insurance Program (NFIP), the Town is required to enforce FEMA's floodplain regulations to reduce flood risk and maintain eligibility for federally backed flood insurance. In AE Flood Zones—classified as high-risk areas—development must meet stringent elevation and construction standards, including but not limited to:

- Residential structures must have the lowest floor elevated to or above the Base Flood Elevation (BFE) shown on current FEMA Flood Insurance Rate Maps (FIRMs).
- Non-residential structures must be either elevated or floodproofed to the BFE.
- All development must avoid obstructing or altering the floodplain in ways that increase flood risk to adjacent properties.
- Proper flood openings, materials, and anchoring methods must be used in accordance with federal and local flood-resistant construction standards.

The permit in question was issued without adequate verification that these requirements had been met. Continuing construction under the current permit would increase flood risk, violate FEMA and Town regulations, and jeopardize the



Town's standing in the NFIP—which could negatively impact flood insurance availability for all Fort Myers Beach property owners.

Next Steps:

We understand the inconvenience this may cause and are committed to assisting you in moving forward in compliance. We recommend consulting with a licensed Florida engineer, architect, or land surveyor experienced in FEMA floodplain regulations.

You may submit revised plans for review once all applicable floodplain development standards have been met.

Our Building Services and Floodplain Management teams are available to answer any questions and provide guidance throughout this process.

Thank you for your understanding and cooperation as we work to protect the safety and resilience of our community.

Sincerely,  
Joe Specht  
Building Official  
Town of Fort Myers Beach

1. **The sink and associated plumbing will have to be removed at the ground level.**

**FBC 1612.4, ASCE 24 7.1**

**1612.4 Design and construction.**

The design and construction of buildings and structures located in flood hazard areas, including coastal high hazard areas and Coastal A Zones, shall be in accordance with Chapter 5 of ASCE 7 and with ASCE 24.

2023 Florida Building Code, Building, Eighth Edition / CHAPTER 16 / SECTION 1612 / 1612.4

2. **A V-Zone certificate is required from the owner. FBC 1612.5**

**1612.5 Flood hazard documentation.**

The following documentation shall be prepared and sealed by a licensed professional surveyor and mapper or a registered design professional, as applicable, and submitted to the building official:

1. For construction in *flood hazard areas* other than *coastal high hazard areas* or *coastal A zones*:
  - 1.1. The elevation of the lowest floor, including the basement, as required by the lowest floor elevation inspection in Section 110.3, Building, 1.1 and for the final inspection in Section 110.3, Building, 5.1.
  - 1.2. For fully enclosed areas below the design flood elevation where provisions to allow for the automatic entry and exit of floodwaters do not meet the minimum requirements in Section 2.7.2.1 of ASCE 24, *construction documents* shall include a statement that the design will provide for equalization of hydrostatic flood forces in accordance with Section 2.7.2.2 of ASCE 24.
  - 1.3. For *dry floodproofed* nonresidential buildings, *construction documents* shall include a statement that the *dry floodproofing* is designed in accordance with ASCE 24 and shall include the flood emergency plan specified in Chapter 6 of ASCE 24.
  - 1.4. For *dry floodproofed* nonresidential buildings, the elevation to which the building is *dry floodproofed* as required for the final inspection in Section 110.3, Building, 6.1.
2. For construction in *coastal high hazard areas* and *coastal A zones*:

2.1.The elevation of the bottom of the lowest horizontal structural member as required by the lowest floor elevation inspection in Section 110.3, Building, 1.1 and for the final inspection in Section 110.3, Building, 5.1.

2.2.*Construction documents* shall include a statement that the building is designed in accordance with ASCE 24, including that the pile or column foundation and building or structure to be attached thereto is designed to be anchored to resist flotation, collapse and lateral movement due to the effects of wind and flood loads acting simultaneously on all building components, and other load requirements of Chapter 16.

2.3.For breakaway walls designed to have a resistance of more than 20 psf (0.96 kN/m<sup>2</sup>) determined using allowable stress design, *construction documents* shall include a statement that the breakaway wall is designed in accordance with ASCE 24.

2.4.For breakaway walls where provisions to allow for the automatic entry and exit of floodwaters do not meet the minimum requirements in Section 2.7.2.1 of ASCE 24, *construction documents* shall include a statement that the design will provide for equalization of hydrostatic flood forces in accordance with Section 2.7.2.2 of ASCE 24.

2023 Florida Building Code, Building, Eighth Edition / CHAPTER 16 / SECTION 1612 / 1612.5

**3. Hydrostatic relief vents are required per the FMB Floodplain Manager's comments. FBC 1612.4, ASCE 4.6.2**

1612.4 Design and construction.

The design and construction of buildings and structures located in flood hazard areas, including coastal high hazard areas and Coastal A Zones, shall be in accordance with Chapter 5 of ASCE 7 and with ASCE 24.

2023 Florida Building Code, Building, Eighth Edition / CHAPTER 16 / SECTION 1612 / 1612.4

**4. All hydrostatic relief vents must kept clear of blockage. FBC 1612.4, ASCE 4.6.2**

1612.4 Design and construction.

The design and construction of buildings and structures located in flood hazard areas, including coastal high hazard areas and Coastal A Zones, shall be in accordance with Chapter 5 of ASCE 7 and with ASCE 24.

2023 Florida Building Code, Building, Eighth Edition / CHAPTER 16 / SECTION 1612 / 1612.4

**5. A corrected Elevation Certificate is required and to be reviewed and approved by the FMB Floodplain Manager. FBC 1612.5**

**1612.5 Flood hazard documentation.**

The following documentation shall be prepared and sealed by a licensed professional surveyor and mapper or a *registered design professional*, as applicable, and submitted to the *building official*:

1. For construction in *flood hazard areas* other than *coastal high hazard areas* or *coastal A zones*:
  - 1.1. The elevation of the lowest floor, including the basement, as required by the lowest floor elevation inspection in Section 110.3, Building, 1.1 and for the final inspection in Section 110.3, Building, 5.1.
  - 1.2. For fully enclosed areas below the design flood elevation where provisions to allow for the automatic entry and exit of floodwaters do not meet the minimum requirements in Section 2.7.2.1 of ASCE 24, *construction documents* shall include a statement that the design will provide for equalization of hydrostatic flood forces in accordance with Section 2.7.2.2 of ASCE 24.
  - 1.3. For *dry floodproofed* nonresidential buildings, *construction documents* shall include a statement that the *dry floodproofing* is designed in accordance with ASCE 24 and shall include the flood emergency plan specified in Chapter 6 of ASCE 24.
  - 1.4. For *dry floodproofed* nonresidential buildings, the elevation to which the building is dry floodproofed as required for the final inspection in Section 110.3, Building, 6.1.
2. For construction in *coastal high hazard areas* and *coastal A zones*:
  - 2.1. The elevation of the bottom of the lowest horizontal structural member as required by the lowest floor elevation inspection in Section 110.3, Building, 1.1 and for the final inspection in Section 110.3, Building, 5.1.
  - 2.2. *Construction documents* shall include a statement that the building is designed in accordance with ASCE 24, including that the pile or column foundation and building or structure to be attached thereto is designed to be anchored to resist flotation, collapse and lateral movement due to the effects of wind and flood loads acting simultaneously on all building components, and other load requirements of Chapter 16.

2.3. For breakaway walls designed to have a resistance of more than 20 psf (0.96 kN/m<sup>2</sup>) determined using allowable stress design, *construction documents* shall include a statement that the breakaway wall is designed in accordance with ASCE 24.

2.4. For breakaway walls where provisions to allow for the automatic entry and exit of floodwaters do not meet the minimum requirements in Section 2.7.2.1 of ASCE 24, *construction documents* shall include a statement that the design will provide for equalization of hydrostatic flood forces in accordance with Section 2.7.2.2 of ASCE 24.

2023 Florida Building Code, Building, Eighth Edition / CHAPTER 16 / SECTION 1612 / 1612.5

CODE COMPLIANCE SPECIAL MAGISTRATE  
THE TOWN OF FORT MYERS BEACH, FLORIDA

TOWN OF FORT MYERS BEACH,  
a Florida municipal corporation,

Petitioner,

vs.

FMB CASE NO. 20250800

B + B PROPERTIES OF FORT MYERS, LLC

Respondent.

\_\_\_\_\_ /

ORDER OF CONTINUANCE

The undersigned hereby gives notice that the Honorable Judge John G. Van Laningham continued a hearing in the above case at the Fort Myers Beach Council Chambers from Tuesday, March 3, 2026. The continued hearing will be held on **Tuesday, May 5, 2026, at 9:00 a.m.** at the Town of Fort Myers Beach Town Hall located at 6231 Estero Boulevard, Fort Myers Beach, Lee County, Florida.

Ordered this \_\_\_\_ day of March, 2026.

\_\_\_\_\_  
John G. Van Laningham,  
Special Magistrate

**CERTIFICATE OF SERVICE**

I, the undersigned, hereby certify that true and correct copy of the Order was sent by U.S. Mail on the \_\_\_ day of \_\_\_\_\_ 2026, to:

B + B PROPERTIES OF FORT MYERS, LLC  
21050 SAINT PETERS DR  
FORT MYERS BEACH, FL 33931

Nancy Stuparich: [nstuparich@voselaw.com](mailto:nstuparich@voselaw.com)  
Michael Hauserman: [Michael.Hauserman@fmbgov.com](mailto:Michael.Hauserman@fmbgov.com)  
Amy Baker: [amy@fmbgov.com](mailto:amy@fmbgov.com)

I certify this document to be a true and correct copy of the original on file in Town Hall, Fort Myers Beach, State of Florida, County of Lee.

BY: \_\_\_\_\_  
Town Clerk and Clerk to the Special Magistrate

Dated: \_\_\_\_\_

APPEAL: An aggrieved party may appeal an Order of the Special Magistrate of the Town of Fort Myers Beach to the Lee County Circuit Court. The appeal shall be limited to appellate review of the record created before the Special Magistrate. An appeal shall be filed within thirty (30) days of the execution of the Order to be appealed.

PAYMENT OF ADMINISTRATIVE COSTS, LIENS OR FINES: Checks should be made payable to "Town of Fort Myers Beach," include the case number and mail to:

Town of Fort Myers Beach  
Attention: Code Enforcement  
6231 Estero Boulevard  
Fort Myers Beach, FL 33931

**Property Address and Owner:**

**Hearing Date: March 3, 2026**

Property Owner: Bryan G & Christine Dawn Thomas  
FMB Case # 20250802  
Property Address: 263 Palermo Circle  
Violation: Lack of current valid building permit and building code deficiencies.  
Officer: M. Hauserman  
**Request to Continue to August 5, 2026 Hearings**

**Subject:**

**Code Section:**

**Reference Number:**

**Strap Number:**

**Officer:**

---

**Narrative:**

Working with Permitting on listed violations. Rescheduled per email request from law firm.

**Attachments:**

1. 20250802\_263 Palermo Cir\_Exhibit A\_Notice of Violation and Hearing Affidavit Ownership
2. 20250802\_263 Palermo Cir\_Notice of Representation
3. 20250802\_263 Palermo Circle\_Notice of Continued Hearing -

**Town Recommendations:**

**Town Approvals:**

_____	Date: February 25, 2026
Michael Hauserman, Code Compliance Manager	
_____	Date: February 25, 2026
Thomas Yozzo, Emergency Services Director	
	
_____	Date: February 25, 2026
Traci Kohler, Deputy Town Manager	
_____	Date: February 25, 2026
nancy stuparich, Town Attorney	
_____	Date: February 25, 2026
Lizzette Roman, Town Clerk Administrative Coordinator	
_____	Date: February 25, 2026
Amy Baker, Town Clerk	

# EXHIBIT A

- Notice of Violation & Hearing
- Evidence of Service
  - Affidavit of Positing
  - Evidence of Posting at violation address
  - Evidence of Posting at Town Hall
  - Evidence of Mailing / Certified Mail
- Evidence of Ownership
  - Lee County Property Appraisers
  - Tax Bill
- Initial Inspection Evidence
  - Photographs
  - Permit records
  - Other Evidence



Town of Fort Myers Beach

6231 Estero Blvd, Florida 33931  
Phone: 239-765-0202 Fax: 239-765-0909

TOWN OF FORT MYERS BEACH,  
FLORIDA,

Petitioner,  
vs.

<b>Certified Mail: 9589071052703142134340</b>
<b>Regular Mail: USPS 11/13/2025</b>

BRYAN G & CHRISTINE DAWN  
THOMAS  
Respondent.

\_\_\_\_\_ /

**AFFIDAVIT OF NOTICE AND POSTING**

STATE OF FLORIDA  
COUNTY OF LEE

BEFORE ME, the undersigned authority, personally appeared Michael J Hauserman, who being duly sworn by me, on oath, deposes and says the following regarding that certain Notice of Violation and Notice of Hearing attached hereto as **Exhibit A** (“the Notice”):

1. My name is Michael J Hauserman. I am over 18 years of age and am competent to testify to the matters set forth herein. I make this Affidavit based upon my personal knowledge.
2. I am employed as the Code Compliance Manager for the Town of Fort Myers Beach (“Town”).
3. On 11/13/2025, I personally mailed a copy of the Notice by certified mail and first-class mail as follows:
  - a. To the property owner at the address listed in the records of the Lee County Tax Collector and/or Lee County Property Appraiser for tax notices, which address is: 263 Palermo Circle, Fort Myers Beach, FL 33931. A true and correct copy of the property ownership and address information obtained from the Tax Collector/Property Appraiser is attached hereto as **Exhibit A**. A copy of the certified mail receipt is attached hereto as **Exhibit A**.

- b. To the following additional address(es) reasonably believed to be valid for the property owner: \_\_\_\_\_. A copy of the certified mail receipt is attached hereto as **Exhibit A**.
- c. The property is owned by \_\_\_\_\_ (business entity name), a business entity registered in the State of Florida. I mailed a copy of the Notice by certified mail and first-class mail to the business entity's Registered Agent, \_\_\_\_\_, at the following address: \_\_\_\_\_. A copy of the certified mail receipt is attached hereto as **Exhibit A**. A true and correct copy of the Florida Division of Corporations record for the entity, identifying its Registered Agent, is attached hereto as **Exhibit A**.

4. On 11/13/2025, I posted a copy of the Notice at 263 Palermo Circle, Fort Myers Beach, FL 33931, which is the property upon which the violation is alleged to exist. Photographs of the posted Notice, taken by me on that date, are attached hereto as **Exhibit A**.

5. On 11/13/2025, I posted a copy of the Notice at Town Hall, located at 6231 Estero Boulevard, Fort Myers Beach, FL 33931, which is the primary municipal government office for the Town of Fort Myers Beach. Photographs of the posted Notice, taken by me on that date, are attached hereto as **Exhibit A**.

Under penalties of perjury, I declare that I have read the foregoing Affidavit and that the facts stated in it are true and to the best of my knowledge and belief comply with Section 2-429 of the Town of Fort Myers Beach Land Development Code and Section 162.12, Florida Statutes.

**SWORN AND ATTESTED BY:**



Signature of Affiant  
Printed Name: Michael J Hauserman  
Title: Code Compliance Manager

The foregoing instrument was sworn to, subscribed and acknowledged before me by means of  physical presence /  online notarization, this 13<sup>th</sup> day of November, 2025 by Michael J Hauserman, who  is personally known to me  or has produced \_\_\_\_\_ as identification.



Notary Public, State of Florida  
Printed Name: Rileigh R Baker  
My Commission No.: HH 637224  
My Commission Expires: 2/5/2029



**Town of Fort Myers Beach**  
**NOTICE OF VIOLATION AND NOTICE OF CODE**  
**ENFORCEMENT HEARING**

6231 Estero Blvd, Fort Myers Beach, FL 33931

Phone: (239) 765-0202

Date: November 13, 2025

Case Number: **20250802**

Property Owner: **BRYAN G & CHRISTINE DAWN THOMAS**  
Mailing Address: 263 Palermo Circle, Fort Myers Beach, FL 33931  
Subject Property Address: **263 Palermo Circle, Fort Myers Beach, FL 33931**  
Certified Mail# 9589071052703142134340  
Parcel: 19-46-24-W4-0060G.0040

YOU ARE HEREBY NOTIFIED that the undersigned Code Officer observed on November 10, 2025 the following violation(s) of the Land Development Code of the Town of Fort Myers Beach, Florida, were present on the subject property identified above:

**Code Violation:** On 11/10/2025, I observed multiple code violations including but not limited to lack of current valid building permit and building code deficiencies as defined in the Fort Myers Beach (FMB) Land Development Code Section 6-111, Florida Building Code (FBC) 105.1, and Section 6-441 of the FMB Land Development Code.

**CHAPTER 6 – MAINTENANCE CODES, BUILDING CODES AND COASTAL REGULATIONS**

**ARTICLE II. BUILDING CODES**

**DIVISION 3. – BUILDING CODE**

**SECTION 6-111. – Adoption; amendments.**

*The Florida Building Code is hereby adopted by reference and made a part of this article, including all revisions and amendments approved in accordance with state law, with the exceptions set forth as follows:*

**FBC 7<sup>th</sup> Edition Section 105 PERMITS 105.1 Required.**

*Any owner or owner's authorized agent who intends to construct, enlarge, alter, repair, move, demolish or change the occupancy of a building or structure, or to erect, install, enlarge, alter, repair, remove, convert or replace any impact-resistant coverings, electrical, gas, mechanical or plumbing system, the installation of which is regulated by this code, or to cause any such work to be performed, shall first make application to the building official and obtain the required permit.*

*FMB Sec. 6 - 441 Permits required Any owner or owner's authorized agent (hereinafter "applicant") who intends to undertake any development activity within the scope of this ordinance, including buildings, structures and facilities exempt from the Florida Building Code, which is wholly within or partially within any flood hazard area shall first make application to the Floodplain Administrator; and the Building Official if applicable, and shall obtain the required permit(s) and approval(s). No such permit or approval shall be issued until compliance with the requirements of the ordinance and all other applicable codes and regulations has been satisfied. No person may undertake a series of any improvements, additions, and/or demolitions that connect two or more existing structures in a manner that evades the requirements of this ordinance and the Florida Building Code.*

Additionally, administrative fees may be requested by the Town to recover all costs incurred by the Town in scheduling and presenting the code enforcement case to the Special Magistrate as ordered by the Special Magistrate. **THE IMPOSITION OF FINES AND/OR ADMINISTRATIVE FEES AND COSTS MAY RESULT IN A FUTURE LIEN AGAINST YOUR PERSONAL AND REAL PROPERTY.**

You have the right to be represented by an attorney at the scheduled hearing and to respond and present evidence (documents and testimony by witnesses) at the scheduled hearing. If you wish to be represented by an attorney, your attorney **MUST** notify the Special Magistrate's Clerk in writing at least five (5) working days before the scheduled hearing.

You may also have other rights which are set forth in Division 2 of Article V of Chapter 2 of the Town Land Development Code. If a person decides to appeal any decision with respect to any matter considered at the scheduled hearing, such person will need to ensure that a verbatim record of the proceedings is made, which includes the testimony and evidence upon which the appeal is to be based (Section 286.0105, Florida Statutes).

For additional information, contact the Town of Fort Myers Beach Special Magistrate Clerk at (239) 765-4222.

Michael J Hauserman



---

Code Enforcement Manager  
Fort Myers Beach, Florida  
239-478-9363

U.S. Postal Service™ 20210802  
**CERTIFIED MAIL® RECEIPT**  
Domestic Mail Only

For delivery information, visit our website at [www.usps.com](http://www.usps.com)

**OFFICIAL USE**

9569 0710 5270 3142 1343 40

Certified Mail Fee	\$
Extra Services & Fees (check box, add fee as appropriate)	
<input type="checkbox"/> Return Receipt (hardcopy)	\$
<input type="checkbox"/> Return Receipt (electronic)	\$
<input type="checkbox"/> Certified Mail Restricted Delivery	\$
<input type="checkbox"/> Adult Signature Required	\$
<input type="checkbox"/> Adult Signature Restricted Delivery	\$

Postage	\$
Total Postage and Fees	\$

11-13-25  
MIT ✓  
Postmark  
Here

Sent To	Bryan G & Christine Dawn Thomas
Street and	263 Palermo Circle
City, State	Fort Myers Beach, FL 33931

PS Form 3800, January 2023 PSN 7530-02-000-9047 See Reverse for Instructions





Posted 11/13/25  
mt

**Town of Fort Myers Beach**  
**NOTICE OF VIOLATION AND NOTICE OF CODE**  
**ENFORCEMENT HEARING**  
6231 Estero Blvd, Fort Myers Beach, FL 33931  
Phone: (239) 765-0202

Date: November 13, 2025

Case Number: 20250802

Property Owner: **BRYAN G & CHRISTINE DAWN THOMAS**  
Mailing Address: 263 Palermo Circle, Fort Myers Beach, FL 33931  
Subject Property Address: 263 Palermo Circle, Fort Myers Beach, FL 33931  
Certified Mail# 9589071052703142134340  
Parcel: 19-46-24-W4-0060G.0040

YOU ARE HEREBY NOTIFIED that the undersigned Code Officer observed on November 10, 2025 the following violation(s) of the Land Development Code of the Town of Fort Myers Beach, Florida, were present on the subject property identified above:

**Code Violation:** On 11/10/2025, I observed multiple code violations including but not limited to lack of current valid building permit and building code deficiencies as defined in the Fort Myers Beach (FMB) Land Development Code Section 6-111, Florida Building Code (FBC) 105.1, and Section 6-441 of the FMB Land Development Code.

**CHAPTER 6 – MAINTENANCE CODES, BUILDING CODES AND COASTAL REGULATIONS**  
**ARTICLE II. BUILDING CODES**  
**DIVISION 3. – BUILDING CODE**  
**SECTION 6-111. – Adoption; amendments.**

*The Florida Building Code is hereby adopted by reference and made a part of this article, including all revisions and amendments approved in accordance with state law, with the exceptions set forth as follows:*

**FBC 7<sup>th</sup> Edition Section 105 PERMITS 105.1 Required.**

*Any owner or owner's authorized agent who intends to construct, enlarge, alter, repair, move, demolish or change the occupancy of a building or structure, or to erect, install, enlarge, alter, repair, remove, convert or replace any impact-resistant coverings, electrical, gas, mechanical or plumbing system, the installation of which is regulated by this code, or to cause any such work to be performed, shall first make application to the building official and obtain the required permit.*

*FMB Sec. 6 - 441 Permits required Any owner or owner's authorized agent (hereinafter "applicant") who intends to undertake any development activity within the scope of this ordinance, including buildings, structures and facilities exempt from the Florida Building Code, which is wholly within or partially within any flood hazard area shall first make application to the Floodplain Administrator, and the Building Official if applicable, and shall obtain the required permit(s) and approval(s). No such permit or approval shall be issued until compliance with the requirements of the ordinance and all other applicable codes and regulations has been satisfied. No person may undertake a series of any improvements, additions, and/or demolitions that connect two or more existing structures in a manner that evades the requirements of this ordinance and the Florida Building Code.*

Page 1 of 3

Nov 13, 2025 8:07:39 AM  
Fort Myers Beach

Posted 11-13-25  
MOT



**Town of Fort Myers Beach**  
**NOTICE OF VIOLATION AND NOTICE OF CODE**  
**ENFORCEMENT HEARING**  
6231 Estero Blvd, Fort Myers Beach, FL 33931  
Phone: (239) 765-0202

Date: November 13, 2025

Case Number: 20250802

Property Owner: **BRYAN G & CHRISTINE DAWN THOMAS**  
Mailing Address: 263 Palermo Circle, Fort Myers Beach, FL 33931  
Subject Property Address: 263 Palermo Circle, Fort Myers Beach, FL 33931  
Certified Mail# 9589071052703142134340  
Parcel: 19-46-24-W4-0060G.0040

YOU ARE HEREBY NOTIFIED that the undersigned Code Officer observed on November 10, 2025 the following violation(s) of the Land Development Code of the Town of Fort Myers Beach, Florida, were present on the subject property identified above:

**Code Violation:** On 11/10/2025, I observed multiple code violations including but not limited to lack of current valid building permit and building code deficiencies as defined in the Fort Myers Beach (FMB) Land Development Code Section 6-111, Florida Building Code (FBC) 105.1, and Section 6-441 of the FMB Land Development Code.

**CHAPTER 6 – MAINTENANCE CODES, BUILDING CODES AND COASTAL REGULATIONS**  
**ARTICLE II. BUILDING CODES**  
**DIVISION 3 – BUILDING CODE**  
**SECTION 6-111. – Adoption; amendments.**

*The Florida Building Code is hereby adopted by reference and made a part of this article, including all revisions and amendments approved in accordance with state law, with the exceptions set forth as follows.*

**FBC 7th Edition Section 105 PERMITS 105.1 Required.**

*Any owner or owner's authorized agent who intends to construct, enlarge, alter, repair, move, demolish, or change the occupancy of a building or structure, or to erect, install, enlarge, alter, repair, remove, connect or reinforce any impact-resistant curbs, electrical, gas, mechanical or plumbing system, the installation of which is regulated by this code, or to cause any such work to be performed, shall first make an application to the building official and obtain the required permit.*

**FMB Sec 6-441 Permits required.** *Any owner or owner's authorized agent (hereinafter "applicant") who intends to undertake any development activity within the scope of this ordinance, including buildings, structures and facilities exempt from the Florida Building Code, which is wholly within or partially within any FMB jurisdiction shall first make application to the Planning Administrator, and the Building Official if applicable, and shall obtain the required permit(s) and approvals. No such permit or approval shall be issued until compliance with the requirements of the ordinance and all other applicable codes and regulations has been satisfied. The permit may include a series of any improvements, additions, and/or alterations that conform to or improve existing structures in a manner that meets the requirements of this ordinance and the Florida Building Code.*

Nov 13, 2025 11:24:54 AM  
Fort Myers Beach



# Property Data

STRAP: 19-46-24-W4-0060G.0040 Folio ID: 10599503

Tax Roll Value Letter 2025

Generated on 11/10/2025 1:54 PM

## Owner Of Record - Tenants by Entirety

[\[Change Mailing Address\]](#)



THOMAS G BRYAN &  
THOMAS DAWN CHRISTINE  
263 PALERMO CIR  
FORT MYERS BEACH FL 33931

## Site Address

Site Address maintained by [E911 Program Addressing](#)

263 PALERMO CIR  
FORT MYERS BEACH FL 33931

## Property Description

Do not use for legal documents!



VENETIAN GARDENS BLK G PB 6 PG 70 LOTS 4 + 5

[View Recorded Plat at LeeClerk.org](#) - Use this link to do an Official Records search on the Lee County Clerk of Courts website, using 6 and 70 for the book and page numbers.

### Attributes and Location Details

Total Bedrooms / Bathrooms	4 / 4.0
Gross Living Area	4,206
1st Year Building on Tax Roll	2015
Historic Designation	No

<b>Township</b>	<b>Range</b>	<b>Section</b>	<b>Block</b>	<b>Lot</b>
46	24E	19		
<b>Municipality</b>	<b>Latitude</b>	<b>Longitude</b>		
Town of Fort Myers Beach	26.45496	-81.95194		

[View Parcel on Google Maps](#)

## [ Tax Map Viewer ] [ View Comparables ]



## [ Pictometry Aerial Viewer ]

## Image of Structure



◀ Photo Date May of 2025 ▶  View other photos

Last Inspection Date: 05/15/2025

## Property Values / Exemptions / TRIM Notices

Generated on 11/10/2025 1:54 PM

Exemption	Amount
Homestead Exemption	25,000.00
Additional Homestead Exemption	25,722.00

[2025 Homestead Exemption Renewal Card](#)

TRIM Notices	Tax Year	Just	Land	Market Assessed	Capped Assessed	Exemptions	Classified Use	Taxable
<a href="#">2025 / Additional Info</a>	2025 (Final Value)	2,668,777	1,480,758	2,668,777	1,607,607	50,722	0	1,556,885

2024 / Additional Info	2024 (Final Value)	2,555,835	1,617,889	2,555,835	1,430,424	50,000	0	1,380,424
2023 / Additional Info	2023 (Final Value)	565,557	565,547	565,557	565,557	50,000	0	515,557
2022 / Additional Info	2022 (Final Value)	2,395,914	813,272	2,395,914	1,348,312	50,000	0	1,298,312
2021 / Additional Info	2021 (Final Value)	1,673,224	750,324	1,673,224	1,283,768	50,000	0	1,233,768
2020 / Additional Info	2020 (Final Value)	1,215,306	641,406	1,215,306	1,215,306	50,000	0	1,165,306

The **Just** value is the total parcel assessment (less any considerations for the cost of sale). This is the closest value to *Fair Market Value* we produce and is dated as of January 1st of the tax year in question (F.A.C. 12D-1.002).

The **Land** value is the portion of the total parcel assessment attributed to the land.

The **Market Assessed** value is the total parcel assessment (less any considerations for the cost of sale) based upon the assessment standard. Most parcels are assessed based either upon the *Highest and Best Use* standard or the *Present Use* standard (F.S. 193.011) . For *Agriculturally Classified* parcels (or parts thereof), only agricultural uses are considered in the assessment (F.S. 193.461 (6) (a)). The difference between the *Highest and Best Use/Present Use* and the *Agricultural Use* is often referred to as the *Agricultural Exemption*.  
(i.e. Market Assessed = Just - Agricultural Exemption)

The **Capped Assessed** value is the *Market Assessment* after any *Save Our Homes* or *10% Assessment Limitation* cap is applied. This assessment cap is applied to all properties and limits year-to-year assessment increases to either the *Consumer Price Index* or 3%, whichever is lower for *Homestead* properties OR 10% for non-*Homestead* properties.

The **Exemptions** value is the total amount of all exemptions on the parcel.

The **Taxable** value is the *Capped Assessment* after exemptions (*Homestead, etc.*) are applied to it. This is the value that most taxing authorities use to calculate a parcel's taxes.  
(i.e. Taxable = Capped Assessed - Exemptions)

## Property Details (Current as of 11/9/2025)

Generated on 11/10/2025 1:54 PM

### Land

#### Land Tracts

Use Code	Use Code Description	Number of Units	Unit of Measure
131	Single Family Residential, Canal	5872.00	Square Feet
131	Single Family Residential, Canal	6230.00	Square Feet

#### Land Features

Description	Year Added	Units
DOCK - BOAT - WOODEN	2002	440
SEAWALL - CONCRETE	2014	100
SEAWALL - RIPRAP	2014	100
FENCE - ALUM/VINYL - 4 FEET	2015	100
SEAWALL - CONCRETE	2007	48
DOCK - BOAT - WOODEN	2020	300
BOAT LIFT	2020	1
FENCE - WOOD - SOLID BOARD	2024	90
GATE ELECTRIC	2024	1

### Buildings

#### Building 1 of 1

#### Building Characteristics

Improvement Type	Model Type	Stories	Living Units
100 - Colonial	1 - SINGLE FAMILY RESIDENTIAL	2.0	1

**Bedrooms**

4

**Bathrooms**

4.0

**Year Built**

2015

**Effective Year Built**

2019

**Building Subareas**

Description	Heated / Under Air	Area (Sq Ft)
BAL - BALCONY	N	5
BAS - BASE	Y	1,788
BAS - BASE	Y	479
CFL - CATHEDRAL FLOOR AREA	Y	89
FLG - FINISHED LOWER GARAGE	N	585
FLL - FINISHED LOWER LEVEL	N	1,159
FLU - FINISHED LOWER UTILITY	N	195
FOP - FINISHED OPEN PORCH	N	639
FOP - FINISHED OPEN PORCH	N	114
FOP - FINISHED OPEN PORCH	N	540
FST - FINISHED UTILITY	N	256
FUS - FINISHED UPPER STORY	Y	1,850
JAZ - JACUZZI	N	100
LCP - LOWER CARPORT / OPEN PORCH	N	540
PLR - POOL RESIDENTIAL	N	501
PPT - POOL PATIO	N	1,389

**Building Features**

Description	Year Added	Units
POOL HEATER	2015	1
OUTDOOR KITCHEN	2015	1
ELEVATOR - RESIDENTIAL	2015	1
OUTDOOR SHOWER	2015	1
POOL - RESIDENTIAL	2024	501
PATIO - NATURAL STONE/TRAV	2025	1,098
JACUZZI - TYPE C	2025	1
PATIO UNIMPROVED	2025	300

**Building Front Photo**



**Photo Date: May of 2025**

**Building Footprint**

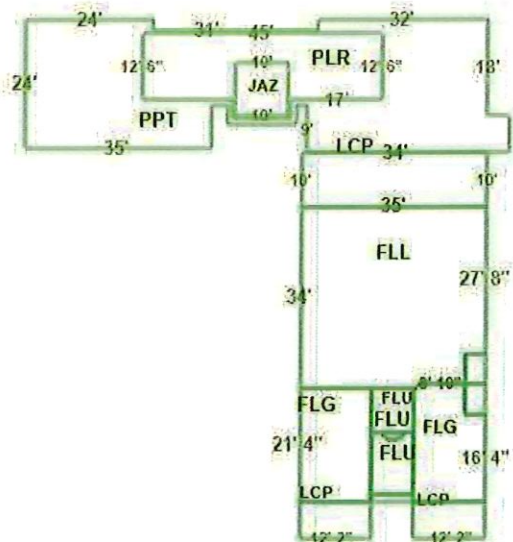

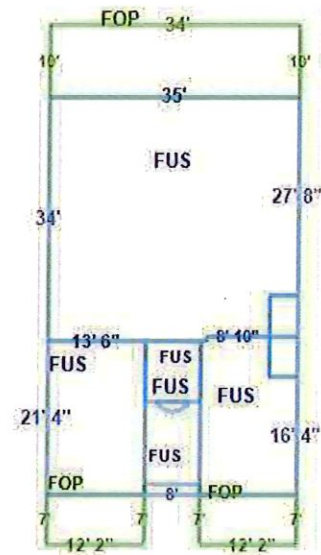
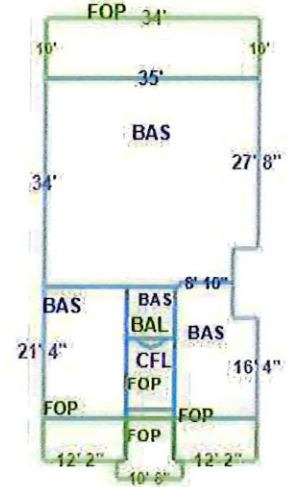
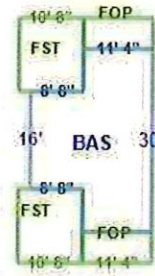

**Property Details (2025 Tax Roll)**

Generated on 11/10/2025 1:54 PM

**Land**

**Land Tracts**

Use Code	Use Code Description	Number of Units	Unit of Measure
131	Single Family Residential, Canal	5872.00	Square Feet
131	Single Family Residential, Canal	6230.00	Square Feet

**Land Features**

Description	Year Added	Units
DOCK - BOAT - WOODEN	2002	440
SEAWALL - CONCRETE	2014	100
SEAWALL - RIPRAP	2014	100
FENCE - ALUM/VINYL - 4 FEET	2015	100

SEAWALL - CONCRETE	2007	48
DOCK - BOAT - WOODEN	2020	300
BOAT LIFT	2020	1
FENCE - WOOD - SOLID BOARD	2024	90
GATE ELECTRIC	2024	1

**Buildings**

**Building 1 of 1**

**Building Characteristics**

Improvement Type	Model Type	Stories	Living Units
100 - Colonial	1 - SINGLE FAMILY RESIDENTIAL	2.0	1
Bedrooms	Bathrooms	Year Built	Effective Year Built
4	4.0	2015	2019

**Building Subareas**

Description	Heated / Under Air	Area (Sq Ft)
BAL - BALCONY	N	5
BAS - BASE	Y	1,788
BAS - BASE	Y	479
CFL - CATHEDRAL FLOOR AREA	Y	89
FLG - FINISHED LOWER GARAGE	N	585
FLL - FINISHED LOWER LEVEL	N	1,159
FLU - FINISHED LOWER UTILITY	N	195
FOP - FINISHED OPEN PORCH	N	639
FOP - FINISHED OPEN PORCH	N	114
FOP - FINISHED OPEN PORCH	N	540
FST - FINISHED UTILITY	N	256
FUS - FINISHED UPPER STORY	Y	1,850
JAZ - JACUZZI	N	100
LCP - LOWER CARPORT / OPEN PORCH	N	540
PLR - POOL RESIDENTIAL	N	501
PPT - POOL PATIO	N	1,389

**Building Features**

Description	Year Added	Units
POOL HEATER	2015	1
OUTDOOR KITCHEN	2015	1
ELEVATOR - RESIDENTIAL	2015	1
OUTDOOR SHOWER	2015	1
POOL - RESIDENTIAL	2024	501
PATIO - NATURAL STONE/TRAV	2025	1,098
JACUZZI - TYPE C	2025	1
PATIO UNIMPROVED	2025	300

**Building Front Photo**

**Building Footprint**

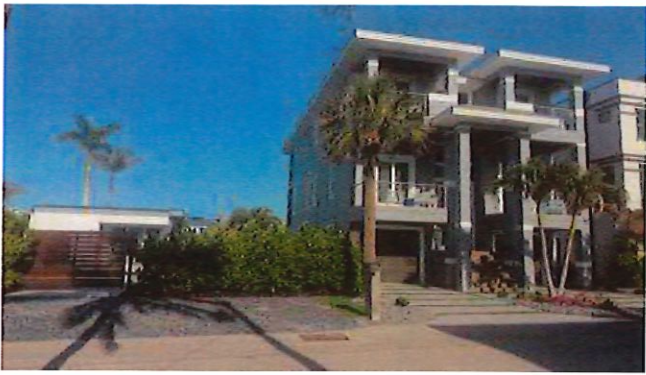
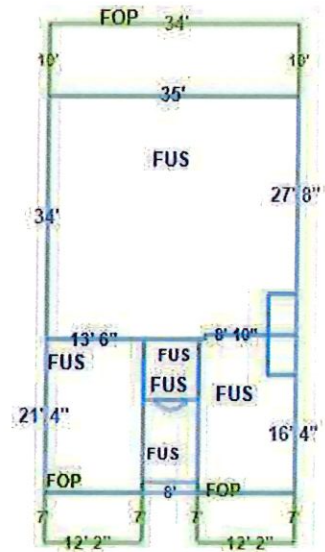
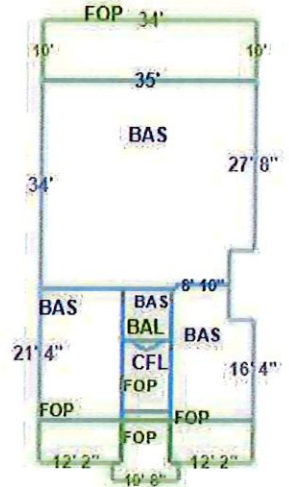
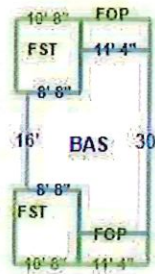
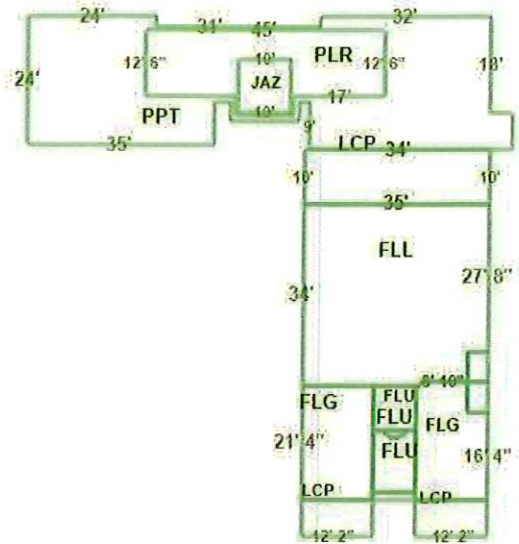

Photo Date: May of 2025



## Taxing Authorities

Generated on 11/10/2025 1:54 PM

### TOWN OF FT MYERS BEACH / 032

Name / Code	Category	Mailing Address
LEE CO GENERAL REVENUE / 044	County	LEE COUNTY OFFICE OF MGMT & BUDGET PO BOX 398 FORT MYERS FL 33902-0398
FORT MYERS BEACH FIRE CONTROL DIST / 032	Independent District	FORT MYERS BEACH FIRE CONTROL DIST 100 VOORHIS ST FORT MYERS BEACH FL 33931
FORT MYERS BEACH MOSQUITO CONTROL / 035	Independent District	FORT MYERS BEACH MOSQUITO CONTROL PO BOX 2837 FORT MYERS BEACH FL 33932-2837
FORT MYERS BEACH PUBLIC LIBRARY DIST / 033	Independent District	FORT MYERS BEACH PUBLIC LIBRARY DIST 2755 ESTERO BLVD FORT MYERS BEACH FL 33931
LEE CO HYACINTH CONTROL DIST / 051	Independent District	LEE CO HYACINTH CONTROL DIST 15191 HOMESTEAD RD LEHIGH ACRES FL 33971
WEST COAST INLAND NAVIGATION DIST / 098	Independent District	WEST COAST INLAND NAVIGATION DIST 200 MIAMI AVE E VENICE FL 34285-2408
TOWN OF FORT MYERS BEACH FLORIDA / 118	Municipal	TOWN OF FORT MYERS BEACH 2523 ESTERO BLVD FORT MYERS BEACH FL 33931
PUBLIC SCHOOL - BY LOCAL BOARD / 012	Public Schools	LEE COUNTY SCHOOL BOARD BUDGET DEPARTMENT 2855 COLONIAL BLVD FORT MYERS FL 33966
PUBLIC SCHOOL - BY STATE LAW / 013	Public Schools	LEE COUNTY SCHOOL BOARD BUDGET DEPARTMENT 2855 COLONIAL BLVD FORT MYERS FL 33966
GREEN CORRIDOR PACE / 363	Special District	
SFWMD-DISTRICT-WIDE / 110	Water District	SFWMD 3301 GUN CLUB RD WEST PALM BEACH FL 33406
SFWMD-EVERGLADES CONSTRUCTION PROJECT / 084	Water District	SFWMD 3301 GUN CLUB RD WEST PALM BEACH FL 33406
SFWMD-OKEECHOBEE BASIN / 308	Water District	SFWMD 3301 GUN CLUB RD WEST PALM BEACH FL 33406

## Sales / Transactions

Generated on 11/10/2025 1:54 PM

Sale Price	Date	Clerk File Number	Type	Notes	Vacant/ Improved
0.00	07/14/2020	20201071693CM		<b>Not a Sale</b> Parcel has been split or combined at the request of the property owner. <a href="#">Click Here for staff assistance.</a>	I
485,000.00	04/28/2020	2020000103167	03		V

[View Recorded Plat at LeeClerk.org](#)

Use the above link to do a search on the Lee County Clerk of Courts website, using **6** and **70** for the book and page numbers and **Plats Book** for the book type.

Help safeguard your home against property fraud. Sign up for the Lee Clerk's free [Property Fraud Alert](#).

## Building / Construction Permit Data

Generated on 11/10/2025 1:54 PM

Permit Number	Permit Type	Date
251392	Building Window / Door Replacement	08/25/2025
242724	Gas	11/06/2024
242758	Building Remodel / Repair	11/05/2024
211488	Building New Construction	05/18/2022
220306	Pool & Spa	05/18/2022
210482	Boathouse, Dock & Shoreline	03/30/2021
201265	Demolition	11/13/2020
201303	Boathouse, Dock & Shoreline	10/02/2020
DRV15-0067	Site Development - Driveway / Sidewalks	04/06/2016
ELE15-0305	Electric	09/29/2015
POL15-0018	Pool & Spa	09/24/2015
FIR15-0022	Gas	05/12/2015
ROF15-0048	Roof	04/30/2015
MEC14-0364	AC New / Change out	12/18/2014
ELE14-0330	Electric	11/06/2014
PLB14-0128	Plumbing	09/26/2014
DEM14-0015	Demolition	08/28/2014
EM14-0015	Demolition	08/28/2014
DEM14-0016	Demolition	08/12/2014
DSH14-0063	Boathouse, Dock & Shoreline	08/08/2014
BLD13-0131	Building New Construction	07/22/2014
DSH2002-00150	Boathouse, Dock & Shoreline	11/09/2007
RES2003-04194	Residential	05/12/2003
DSH2002-00151	Boathouse, Dock & Shoreline	02/27/2002

**IMPORTANT: THIS MAY NOT BE A COMPREHENSIVE OR TIMELY LISTING OF PERMITS ISSUED FOR THIS PROPERTY.**

Note: The Lee County Property Appraiser's Office does not issue or maintain any permit information. The Building / Construction permit data displayed here represents only those records this Office may find necessary to conduct Property Appraiser business. Use of this information is with the understanding that in no way is this to be considered a comprehensive listing of permits for this or any other parcel.

The Date field represents the date the property appraiser received information regarding permit activity; it may or not represent the actual date of permit issuance or completion.

Full, accurate, active and valid permit information for parcels can only be obtained from the [appropriate permit issuing agency](#).

## Parcel Numbering History 📌

Generated on 11/10/2025 1:54 PM

Prior STRAP	Prior Folio ID	Renumber Reason	Renumber Date
19-46-24-W4-0060G.0040	10228127	Combined (With another parcel-Delete Occurs)	07/14/2020
19-46-24-W4-0060G.005A	10566727	Combined (With another parcel-Delete Occurs)	07/14/2020

## Solid Waste (Garbage) Roll Data

Generated on 11/10/2025 1:54 PM

Solid Waste District	Roll Type	Category	Unit / Area	Tax Amount
001 - Service Area 1	R - Residential Category		1	358.45
<b>Collection Days</b>				
<b>Garbage</b>		<b>Recycling</b>		<b>Horticulture</b>
Thursday		Thursday		Thursday

## Flood and Storm Information

Generated on 11/10/2025 1:54 PM

Community	Panel	Version	Date	Evacuation Zone
071C	0554	G	11/17/2022	A

Generated on 11/10/2025 1:54 PM

**DO NOT PAY - THIS IS NOT A BILL**  
**NOTICE OF PROPOSED PROPERTY TAXES**  
**TAX INFORMATION**

10599503  
 THOMAS G BRYAN &  
 THOMAS DAWN CHRISTINE  
 263 PALERMO CIR  
 FORT MYERS BEACH, FL 33931

071051  
 Parcel ID: 19-46-24-W4-0060G.0040  
 VENETIAN GARDENS  
 BLK G PB 6 PG 70  
 LOTS 4 + 5  
 263 PALERMO CIR

The taxing authorities which levy property taxes against your property will soon hold PUBLIC HEARINGS to adopt budgets and tax rates for the next year.

The purpose of these PUBLIC HEARINGS is to receive opinions from the general public and to answer questions on the proposed tax change and budget PRIOR TO TAKING FINAL ACTION. Each taxing authority may AMEND OR ALTER its proposals at the hearing.

TAXING AUTHORITY		COLUMN 1*		COLUMN 2*		COLUMN 3*
032 TOWN OF FT MYERS BEACH	LAST YEAR'S ACTUAL TAX RATE 2024 (MILLAGE)	YOUR PROPERTY TAXES LAST YEAR 2024	YOUR TAX RATE THIS YEAR IF NO BUDGET CHANGE IS ADOPTED (MILLAGE)	YOUR TAXES THIS YEAR IF NO BUDGET CHANGE IS ADOPTED	THIS YEAR'S PROPOSED TAX RATE 2025 (MILLAGE)	YOUR TAXES IF PROPOSED BUDGET CHANGE IS ADOPTED 2025
<b>COUNTY:</b>						
LEE CO GENERAL REVENUE	3.7623	\$5,193.57	3.6162	\$5,630.01	3.7623	\$5,857.47
<b>SCHOOL:</b>						
PUBLIC SCHOOL - BY LOCAL BOARD	2.2480	\$3,159.39	2.2302	\$3,529.53	2.2480	\$3,557.70
PUBLIC SCHOOL - BY STATE LAW	3.0380	\$4,269.68	3.0139	\$4,769.82	3.0710	\$4,860.19
<b>MUNICIPALITY OR MSTU:</b>						
TOWN OF FORT MYERS BEACH FLORIDA	0.9900	\$1,366.62	0.8954	\$1,394.03	1.2550	\$1,953.89
<b>WATER MANAGEMENT DISTRICT:</b>						
SFWM-DISTRICT-WIDE	0.0948	\$130.86	0.0889	\$138.41	0.0948	\$147.59
SFWM-EVERGLADES CONSTRUCTION PROJECT	0.0327	\$45.14	0.0306	\$47.64	0.0327	\$50.91
SFWM-OKEECHOBEE BASIN	0.1026	\$141.63	0.0961	\$149.62	0.1026	\$159.74
<b>INDEPENDENT SPECIAL DISTRICTS:</b>						
FORT MYERS BEACH FIRE CONTROL DIST	2.8000	\$3,865.19	2.5436	\$3,960.09	2.8000	\$4,359.28
FORT MYERS BEACH MOSQUITO CONTROL	0.1123	\$155.02	0.1018	\$158.49	0.1123	\$174.84
FORT MYERS BEACH PUBLIC LIBRARY DIST	0.1612	\$222.52	0.1464	\$227.93	0.1612	\$250.97
LEE CO HYACINTH CONTROL DIST	0.0200	\$27.61	0.0192	\$29.89	0.0200	\$31.14
WEST COAST INLAND NAVIGATION DIST	0.0394	\$54.39	0.0381	\$59.32	0.0394	\$61.34
<b>TOTAL TAX RATES:</b>	13.4013		12.8204		13.6993	
<b>TOTAL PROPERTY TAXES:</b>		\$18,631.62		\$20,094.78		\$21,465.06
		<b>COLUMN 1*</b>		<b>COLUMN 2*</b>		<b>COLUMN 3*</b>

**NOTICE OF PROPOSED PROPERTY TAXES EXPLANATION (Section 200.069, Florida Statutes)**

**\*COLUMN 1—“YOUR PROPERTY TAXES LAST YEAR”** - This column shows the taxes that applied last year to your property. These amounts were based on budgets adopted last year and your property’s previous taxable value.

**\*COLUMN 2—“YOUR TAXES IF NO BUDGET CHANGE IS ADOPTED”** - This column shows what your taxes will be this year IF EACH TAXING AUTHORITY DOES NOT CHANGE ITS PROPERTY TAX LEVY. These amounts are based on last year’s budgets and your current assessment.

**\*COLUMN 3—“YOUR TAXES IF PROPOSED BUDGET CHANGE IS ADOPTED”** - This column shows what your taxes will be this year under the BUDGET ACTUALLY PROPOSED by each local taxing authority. The proposal is NOT final and may be amended at the public hearings shown on this notice. The difference between Columns 2 and 3 is the tax change proposed by each local taxing authority and is NOT the result of higher assessments.

**NOTE:** Amounts shown on this form do NOT reflect early payment discounts you may have received or may be eligible to receive. (Discounts are a maximum of 4 percent of the amounts shown on this form.)

**NON-AD VALOREM ASSESSMENTS:** Your final tax bill may contain non-ad valorem assessments which may not be reflected on this notice such as assessments for roads, fire, garbage, lighting, drainage, water, sewer, or other governmental services and facilities which may be levied by your county, city, or any special district

**A Public Hearing on the Proposed Taxes and Budget Will Be Held:**

COUNTY/MSTU:	09/04/2025 5:05PM	Lee Co Commission Chambers	2120 Main St	Fort Myers FL 33901	239-533-2221
SCHOOL:	09/09/2025 5:05PM		2855 Colonial Blvd	Fort Myers FL 33966	239-337-8215
MUNICIPALITY:	09/11/2025 5:01PM		6231 Estero Blvd	Fort Myers Beach FL 33931	239-765-0202
WATER MANAGEMENT DISTRICT:	09/11/2025 5:15PM	SFWM Auditorium	3301 Gun Club Rd B-1 Bldg	West Palm Beach FL 33406	561-686-8800
LEE CO MOSQUITO AND/OR HYACINTH:	09/11/2025 5:01PM/5:15PM		15191 Homestead Rd	Lehigh Acres FL 33971	239-694-2174
FORT MYERS BEACH FIRE CONTROL DIST:	09/10/2025 5:05PM	Diamond Head Resort	2000 Estero Blvd	Ft Myers Beach FL 33931	239-590-4200
FORT MYERS BEACH MOSQUITO CONTROL:	09/03/2025 5:01PM		161 Bay Rd	Ft Myers Beach FL 33931	239-247-1205
FORT MYERS BEACH PUBLIC LIBRARY DIST:	09/11/2025 5:05PM		2755 Estero Blvd	Ft Myers Beach FL 33931	239-463-9691
WEST COAST INLAND NAVIGATION DISTRICT:	09/05/2025 5:01PM		1575 E Venice Ave	Venice FL 34292	941-485-9402

\*\* PROPERTY RECORD UPDATE -- WEBSITE AND PERSONALIZED CODE FOR 2025\*\*

Enter your [personalized code TRA1BC4F](#) to review your property details and

- Report or update hurricane damage

- Confirm or update your homestead exemption status
- Discover how your value was impacted

**PROPERTY VALUATION**

	<b>Last Year 2024</b> ⓘ	<b>This Year 2025</b> ⓘ
<b>MARKET VALUE</b>	<b>\$2,555,835</b>	<b>\$2,668,777</b>

**Market Value** in Florida is also known as "just value" as provided by the constitution and described in state law. It is the amount a purchaser willing but not obliged to buy would pay to one willing but not obliged to sell, after proper consideration of all eight factors in section 193.011, F.S.

<b>ASSESSED VALUE</b>	
-----------------------	--

**Assessed Value** is the market value of your property minus the amount of any assessment reductions. The assessed value may be different for millage levies made by different taxing authorities.

<b>ASSESSMENT REDUCTIONS</b>	<b>APPLIES TO</b>	<b>VALUE</b>
------------------------------	-------------------	--------------

**Assessment Reduction** amounts are based on applicable statutory limitations and benefits that may affect the Assessed Value, such as the Save Our Homes cap or an Agricultural Classification. The value of these limitations and benefits make up the difference between market and assessed value.

Save Our Homes Benefit	All Levies	\$1,061,170
------------------------	------------	-------------

<b>EXEMPTIONS</b>	<b>APPLIES TO</b>	<b>VALUE</b>
-------------------	-------------------	--------------

**Exemptions** are specific dollar or percentage amounts that reduce taxable value. These are usually based on characteristics of the property or property owner. Examples include the homestead exemption, veterans' disability exemptions and charitable exemptions. In some cases, the maximum exemption amount may not be applied because of a lower assessed value. Many exemptions apply only to tax levies by the taxing authority granting the exemption.

Homestead Exemption	Adopted Levies	\$25,000
Additional Homestead Exemption	Adopted Levies	\$25,722

<b>VALUE CALCULATIONS</b>	
---------------------------	--

**Taxable Value** is the assessed value minus qualifying exemptions. This is the value used to calculate the tax due on your property. The assessed and taxable values may vary by taxing authority because certain assessment reductions and exemptions may not apply to all levies and discounts.

TAXING AUTHORITY	ASSESSED VALUE		EXEMPTIONS		TAXABLE VALUE	
	LAST YEAR	THIS YEAR	LAST YEAR	THIS YEAR	LAST YEAR	THIS YEAR ⓘ
<b>COUNTY:</b>						
LEE CO GENERAL REVENUE	\$1,430,424	\$1,607,607	\$50,000	\$50,722	\$1,380,424	\$1,556,885
<b>SCHOOL:</b>						
PUBLIC SCHOOL - BY LOCAL BOARD	\$1,430,424	\$1,607,607	\$25,000	\$25,000	\$1,405,424	\$1,582,607
PUBLIC SCHOOL - BY STATE LAW	\$1,430,424	\$1,607,607	\$25,000	\$25,000	\$1,405,424	\$1,582,607
<b>MUNICIPALITY OR MSTU:</b>						
TOWN OF FORT MYERS BEACH FLORIDA	\$1,430,424	\$1,607,607	\$50,000	\$50,722	\$1,380,424	\$1,556,885
<b>WATER MANAGEMENT DISTRICT:</b>						
SFWM-DISTRICT-WIDE	\$1,430,424	\$1,607,607	\$50,000	\$50,722	\$1,380,424	\$1,556,885
SFWM-EVERGLADES CONSTRUCTION PROJECT	\$1,430,424	\$1,607,607	\$50,000	\$50,722	\$1,380,424	\$1,556,885
SFWM-OKEECHOBEE BASIN	\$1,430,424	\$1,607,607	\$50,000	\$50,722	\$1,380,424	\$1,556,885
<b>INDEPENDENT SPECIAL DISTRICTS:</b>						
FORT MYERS BEACH FIRE CONTROL DIST	\$1,430,424	\$1,607,607	\$50,000	\$50,722	\$1,380,424	\$1,556,885
FORT MYERS BEACH MOSQUITO CONTROL	\$1,430,424	\$1,607,607	\$50,000	\$50,722	\$1,380,424	\$1,556,885
FORT MYERS BEACH PUBLIC LIBRARY DIST	\$1,430,424	\$1,607,607	\$50,000	\$50,722	\$1,380,424	\$1,556,885
LEE CO HYACINTH CONTROL DIST	\$1,430,424	\$1,607,607	\$50,000	\$50,722	\$1,380,424	\$1,556,885
WEST COAST INLAND NAVIGATION DIST	\$1,430,424	\$1,607,607	\$50,000	\$50,722	\$1,380,424	\$1,556,885

If you feel the market value of your property is inaccurate or does not reflect fair market value, or if you are entitled to an exemption or classification that is not reflected on this form, please call us at **(239) 533-6100** or visit the Lee County Property Appraiser's office at 2480 Thompson Street, 4th Floor, Fort Myers, FL.

If we are unable to resolve a matter as to the market value, classification, or an exemption, you may file a petition for adjustment with the Value Adjustment Board. ⓘ Online filing is available at [www.leeclerk.org](http://www.leeclerk.org). Petition forms are available from the Lee County Property Appraiser's office. All petitions must be filed with the Clerk of Courts Office on or before **September 12, 2025**.

**\*\* PROPERTY RECORD UPDATE -- WEBSITE AND PERSONALIZED CODE FOR 2025\*\***

Enter your [personalized code TRA1BC4F](#) to review your property details and

- Report or update hurricane damage
- Confirm or update your homestead exemption status
- Discover how your value was impacted

Prepared By and Return To:  
Safe Harbor Title Company  
12734 Kenwood Lane, Suite #93  
Fort Myers FL 33907

File No. 19-0508

Property Appraiser's Parcel I.D. (folio) Number(s)  
19-46-24-W4-0060G.005A

---

### WARRANTY DEED

THIS WARRANTY DEED dated April 28, 2020, by FCG Associates, LLC, a Florida Limited Liability Company, whose post office address is 6045 Cocos Dr, Fort Myers, FL 33908, hereinafter called the grantor, to G. Bryan Thomas and Dawn Thomas, husband and wife, whose post office address is 263 Palermo Circle, Fort Myers Beach, FL 33931, hereinafter called the grantee:

(Wherever used herein the terms "grantor" and "grantee" include all the parties to this instrument and the heirs, legal representatives and assigns of individuals, and the successors and assigns of corporations)

WITNESSETH: That the grantor, for and in consideration of the sum of \$485,000.00 and other valuable consideration, receipt whereof is hereby acknowledged, hereby grants, bargains, sells, aliens, remises, releases, conveys, and confirms unto the grantee, all the certain land situated in Lee County, Florida, to wit:

LOT 5, BLOCK G, VENETIAN GARDENS, ACCORDING TO THE MAP OR PLAT THEREOF AS RECORDED IN PLAT BOOK 6, PAGE 70, PUBLIC RECORDS OF LEE COUNTY, FLORIDA.

Subject to easements, restrictions, reservations and limitations of record, if any.

TO HAVE AND TO HOLD the same in FEE SIMPLE forever.

AND the grantor hereby covenants with said grantee that the grantor is lawfully seized of said land in fee simple; that the grantor has good right and lawful authority to sell and convey said land; that the grantor hereby fully warrants the title to said land and will defend the same against the lawful claims of all persons whomsoever; and that said land is free of all encumbrances, except taxes accruing subsequent to: December 31, 2019.

**WARRANTY DEED**  
(Continued)

IN WITNESS WHEREOF, the said grantor has signed and sealed these presents the day and year first above written.

Signed, sealed and delivered in the presence of:

  
\_\_\_\_\_  
(Witness Signature)

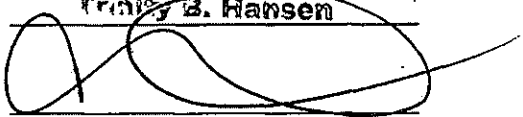
Trinity B. Hansen  
  
\_\_\_\_\_  
(Witness Signature)  
Theresa Stramel

FCG Associates, LLC, a Florida Limited Liability Company

  
\_\_\_\_\_  
By: Gary Baker as Authorized Manager

6045 Cocos Dr  
\_\_\_\_\_  
(Address)

Fort Myers, FL 33908  
\_\_\_\_\_  
(Address)

STATE OF Florida

COUNTY OF Lee

I, Theresa Stramel, a Notary Public of the County and State first above written, do hereby certify that Gary Baker personally appeared before me this day and acknowledged the due execution of the foregoing instrument.

Witness my hand and official seal, this the 28th day of April, 2020.

  
\_\_\_\_\_  
Notary Public

My Commission Expires: 10/26/21

(SEAL)

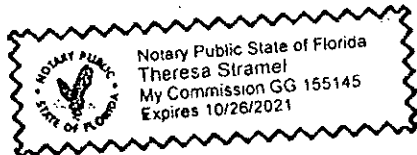



Subject: Revocation of Permit Due to Non-Compliance with Floodplain Requirements in AE Flood Zone

Dear **Thomas G. Bryan**,

This letter serves as formal notice that the Town of Fort Myers Beach is revoking the building permit previously issued for your property located at **263 Palermo Cir Fort Myers Beach, FL 33931**. (STRAP# 194624w40060G0040)

Upon further review, it has been determined that the permit was issued in error. The proposed development is located within a FEMA-designated AE Flood Zone and does not currently meet the floodplain management requirements established by FEMA and adopted by the Town.

Reason for Revocation:

As a participant in the National Flood Insurance Program (NFIP), the Town is required to enforce FEMA's floodplain regulations to reduce flood risk and maintain eligibility for federally backed flood insurance. In AE Flood Zones—classified as high-risk areas—development must meet stringent elevation and construction standards, including but not limited to:

- Residential structures must have the lowest floor elevated to or above the Base Flood Elevation (BFE) shown on current FEMA Flood Insurance Rate Maps (FIRMs).
- Non-residential structures must be either elevated or floodproofed to the BFE.
- All development must avoid obstructing or altering the floodplain in ways that increase flood risk to adjacent properties.
- Proper flood openings, materials, and anchoring methods must be used in accordance with federal and local flood-resistant construction standards.

The permit in question was issued without adequate verification that these requirements had been met. Continuing construction under the current permit would increase flood risk, violate FEMA and Town regulations, and jeopardize the

**FORT MYERS BEACH ESTERO ISLAND**

**P. 239-765-0202 | 6231 Estero Boulevard, Fort Myers Beach, FL 33931**



Apr 14, 2025 9:23:27 AM

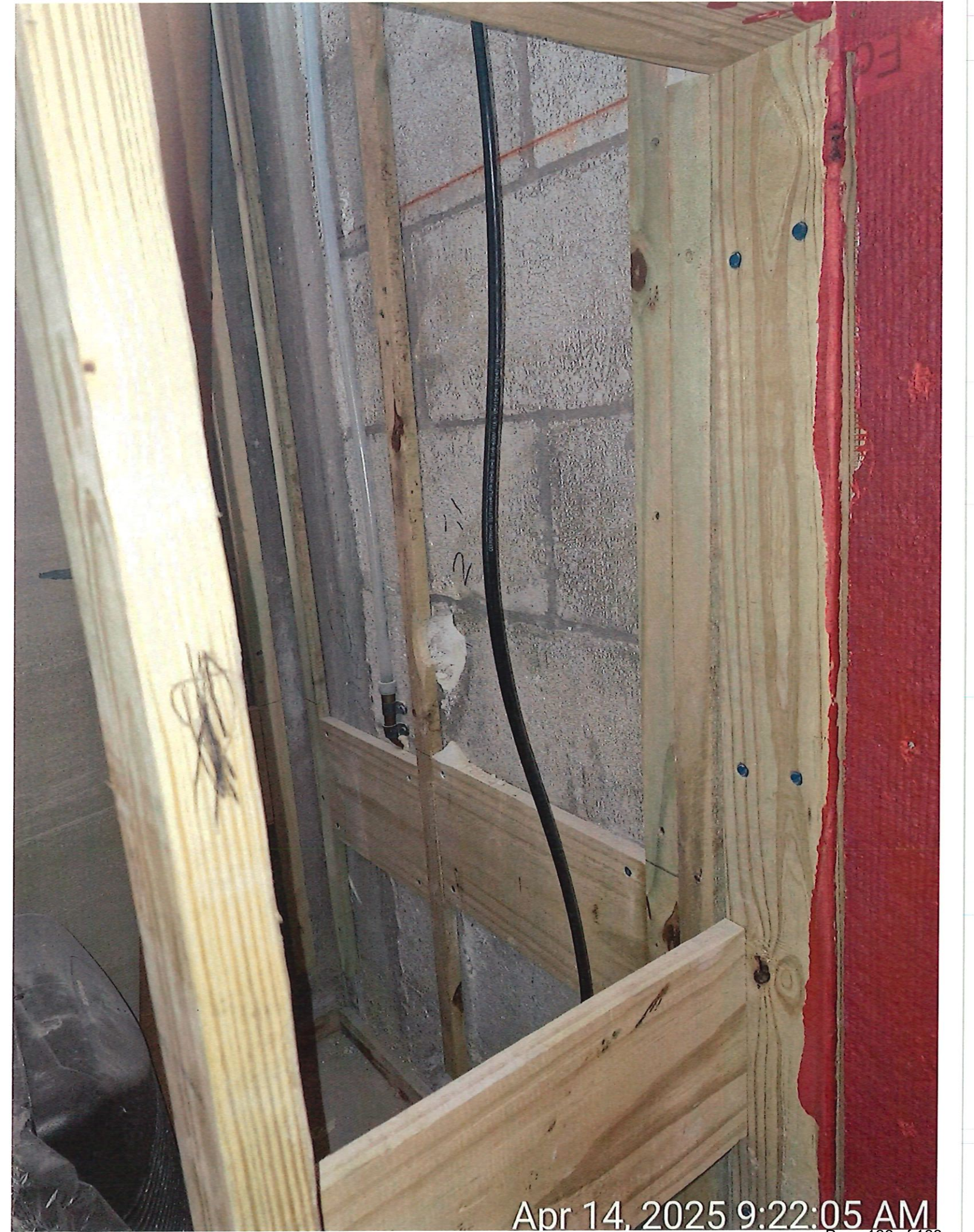

Apr 14, 2025 9:22:05 AM



Apr 14, 2025 9:22:16 AM

Apr 14, 2025 9:22:41 AM

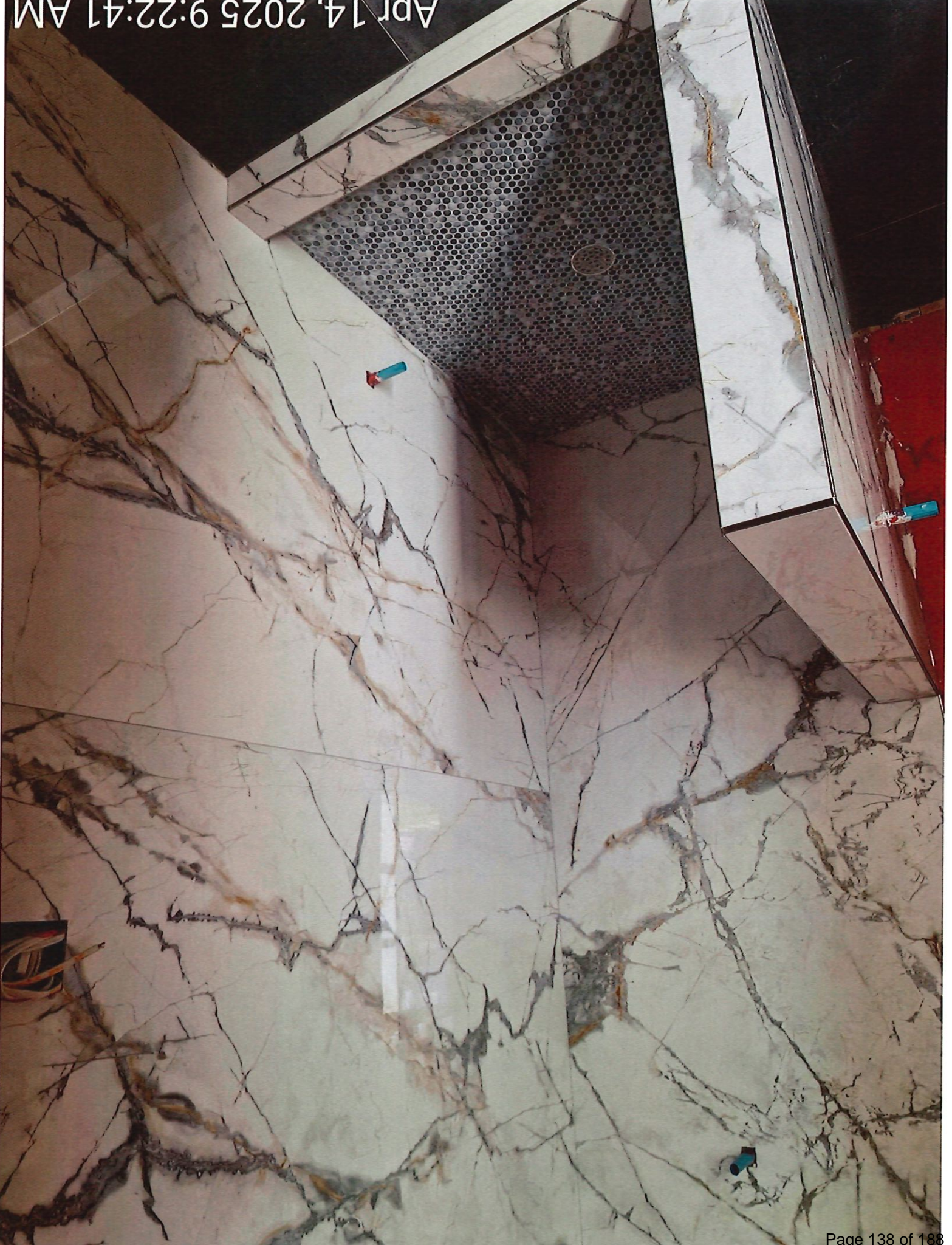



34  
78  
35

Nikki Day | Nikki.Day@gray-robinson.com | D 813.273.5036  
101 East Kennedy Boulevard, Suite 4000, Tampa, Florida 33602 | T 813.273.5000 | F 813.273.5145

December 1, 2025

**VIA PDF E-MAIL ONLY**

Michael J. Hauserman, Code Compliance Manager  
Town of Fort Myers Beach  
6231 Estero Blvd.  
Fort Myers Beach, FL 33931  
[michael.hauserman@fmbgov.com](mailto:michael.hauserman@fmbgov.com)

**Re: Notice of Representation & Request for Extension**  
*Code Compliance Case No. 20250802; Property Address: 263 Palermo Circle*

Dear Mr. Hauserman:

Please be advised that our firm has recently been retained to represent the property owners, Bryan and Dawn Thomas, in the above-referenced code compliance matter. Please direct all future correspondence regarding this case to me.

We are in receipt of the Notice of Violation and Notice of Code Enforcement Hearing dated November 13, 2025. The Notice purports to establish a compliance deadline of Saturday, December 13, 2025.

Given the intricate nature of the alleged violations and the steps necessary to achieve compliance—particularly those related to floodplain management, engineering reviews, and the Town’s revocation of Permit No. 211488—a 30-day timeframe for compliance is not reasonable. Efforts on this matter will require coordination among licensed professionals, in conjunction with the Town’s own professional staff. These processes cannot be completed within the short window provided, especially spanning the holiday season when professional availability is limited.

**As such, we respectfully request an extension of sixty days to the compliance deadline (until Wednesday, February 11, 2026).** We further request that the Special Magistrate hearing currently scheduled for January 7, 2026, be continued and only be reset if this matter is not resolved within the new deadline.

Thank you for your consideration to this request. We look forward to receiving your reply.

Sincerely,

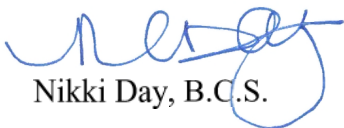

Nikki Day, B.C.S.

CC: Nancy Stuparich, Esq., Town Attorney, [nstuparich@voselaw.com](mailto:nstuparich@voselaw.com)  
Lizzette Roman, Special Magistrate Clerk, [lizzette.roman@fmbgov.com](mailto:lizzette.roman@fmbgov.com)

CODE COMPLIANCE SPECIAL MAGISTRATE  
THE TOWN OF FORT MYERS BEACH, FLORIDA

TOWN OF FORT MYERS BEACH,  
a Florida municipal corporation,

Petitioner,

vs.

FMB CASE NO. 20250802

BRYAN G & CHRISTINE DAWN THOMAS

Respondent.

\_\_\_\_\_ /

ORDER OF CONTINUANCE

The undersigned hereby gives notice that the Honorable Judge John G. Van Laningham continued a hearing in the above case at the Fort Myers Beach Council Chambers from Tuesday, March 3, 2026. The continued hearing will be held on **Tuesday, August 5, 2026, at 9:00 a.m.** at the Town of Fort Myers Beach Town Hall located at 6231 Estero Boulevard, Fort Myers Beach, Lee County, Florida.

Ordered this \_\_\_\_ day of March, 2026.

\_\_\_\_\_  
John G. Van Laningham,  
Special Magistrate

**CERTIFICATE OF SERVICE**

I, the undersigned, hereby certify that true and correct copy of the Order was sent by U.S. Mail on the \_\_\_ day of \_\_\_\_\_ 2026, to:

BRYAN G & CHRISTINE DAWN THOMAS  
263 PALERMO CIRCLE  
FORT MYERS BEACH, FL 33931

Nancy Stuparich: [nstuparich@voselaw.com](mailto:nstuparich@voselaw.com)  
Michael Hauserman: [Michael.Hauserman@fmbgov.com](mailto:Michael.Hauserman@fmbgov.com)  
Amy Baker: [amy@fmbgov.com](mailto:amy@fmbgov.com)

I certify this document to be a true and correct copy of the original on file in Town Hall, Fort Myers Beach, State of Florida, County of Lee.

BY: \_\_\_\_\_  
Town Clerk and Clerk to the Special Magistrate

Dated: \_\_\_\_\_

APPEAL: An aggrieved party may appeal an Order of the Special Magistrate of the Town of Fort Myers Beach to the Lee County Circuit Court. The appeal shall be limited to appellate review of the record created before the Special Magistrate. An appeal shall be filed within thirty (30) days of the execution of the Order to be appealed.

PAYMENT OF ADMINISTRATIVE COSTS, LIENS OR FINES: Checks should be made payable to "Town of Fort Myers Beach," include the case number and mail to:

Town of Fort Myers Beach  
Attention: Code Enforcement  
6231 Estero Boulevard  
Fort Myers Beach, FL 33931

CODE COMPLIANCE SPECIAL MAGISTRATE  
THE TOWN OF FORT MYERS BEACH, FLORIDA

TOWN OF FORT MYERS BEACH,  
a Florida municipal corporation,

Petitioner,

vs.

FMB Case No. 20250819

JOHN K. DANIELS,

Respondent.

\_\_\_\_\_ /

ORDER OF CONTINUANCE

The undersigned hereby gives notice that the Honorable Judge John G. Van Laningham continued a hearing in the above case at the Fort Myers Beach Council Chambers from Tuesday, February 3, 2026. The continued hearing will be held on **Tuesday, March 3, 2026 at 9:00 a.m.** at the Town of Fort Myers Beach Town Hall located at 6231 Estero Boulevard, Fort Myers Beach, Lee County, Florida.

DONE AND ORDERED this 16th day of January 2026.

  
\_\_\_\_\_  
John G. Van Laningham,  
Special Magistrate

**CERTIFICATE OF SERVICE**

I, the undersigned, hereby certify that true and correct copy of the Order was sent by U.S. Mail on the 14<sup>th</sup> day of January 2026, to:

John K. Daniels  
134 West Nimisila Rd.  
Akron, OH 44319

John K. Daniels  
250/252 Bahia Via  
Fort Myers Beach, FL 33931

Nancy Stuparich: [nstuparich@voselaw.com](mailto:nstuparich@voselaw.com)  
Michael Hauserman : [Michael.houserman@fmbgov.com](mailto:Michael.houserman@fmbgov.com)  
Amy Baker: [amy@fmbgov.com](mailto:amy@fmbgov.com)

I certify this document to be a true and correct copy of the original on file in Town Hall, Fort Myers Beach, State of Florida, County of Lee.

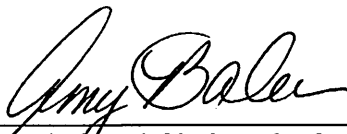
BY:   
Town Clerk and Clerk to the Special Magistrate

Dated: January 16, 2026

**APPEAL:** An aggrieved party may appeal an Order of the Special Magistrate of the Town of Fort Myers Beach to the Lee County Circuit Court. The appeal shall be limited to appellate review of the record created before the Special Magistrate. An appeal shall be filed within thirty (30) days of the execution of the Order to be appealed.

**PAYMENT OF ADMINISTRATIVE COSTS, LIENS OR FINES:** Checks should be made payable to "Town of Fort Myers Beach," include the case number and mail to:

Town of Fort Myers Beach  
Attention: Code Enforcement  
6231 Estero Boulevard  
Fort Myers Beach, FL 33931

CODE COMPLIANCE SPECIAL MAGISTRATE  
THE TOWN OF FORT MYERS BEACH, FLORIDA

TOWN OF FORT MYERS BEACH,  
a Florida municipal corporation,

FMB Case No. 2025019

Petitioner,

vs.

JOHN K. DANIELS,

Respondents.

---

ORDER EXTENDING COMPLIANCE DATE, CONTINUING STATUS REVIEW,  
AND CONFIRMING TAXATION OF COSTS

THIS CAUSE came before the undersigned Administrative Law Judge, John G. Van Laningham, serving as the Special Magistrate for the Town of Fort Myers Beach (“Special Magistrate”), on January 6, 2026, as a duly-noticed status update/fine assessment hearing concerning unpermitted construction/work at the property located at 250/252 Bahia Via, Fort Myers Beach, Florida, which was alleged and previously found to constitute a violation of the Town’s code requirements for obtaining required building permits. The Town appeared through its Code Compliance representative and presented testimony and record materials; a representative appearing on behalf of Respondent was present and provided testimony.

The Special Magistrate, having considered the prior proceedings and the presentations at the January 6, 2026, hearing, and being otherwise fully advised in the premises, hereby FINDS and ORDERS as follows:

1. A prior Special Magistrate Order (signed November 12, 2025) found Respondent in violation concerning construction/work without required permits, established a compliance deadline of December 3, 2025, provided for a daily fine of \$250.00 for noncompliance thereafter, and assessed administrative costs in the amount of \$250.00.
2. At the January 6, 2026, status update hearing, the Town represented that the violation had not been brought into compliance by the prior compliance deadline, and the matter was therefore before the Special Magistrate for further action.
3. Based upon the testimony presented at hearing concerning the status of the permitting review and the progress toward compliance, the compliance date is extended to January

20, 2026, to allow Respondent an additional opportunity to bring the property into compliance.

4. This matter is set for status review at the next regularly scheduled Code Compliance Special Magistrate hearing on February 3, 2026. If the property is brought into compliance prior to that hearing date, Respondent need not appear for further status review, and the remaining administrative actions may be addressed by appropriate written order(s), as necessary.
5. The administrative costs previously assessed in the amount of \$250.00 remain in effect and are confirmed; such costs shall not be reduced or altered by virtue of this extension.

DONE AND ORDERED this 8th day of January, 2026.



John G. Van Laningham,  
Special Magistrate

CERTIFICATE OF SERVICE

I, the undersigned, hereby certify that a true and correct copy of this Order was sent by U.S. Mail on the 8th day of January, 2026, to:

John K. Daniels  
250/252 Bahia Via  
Fort Myers Beach , FL 33931

John K. Daniels  
134 West Nimisila Rd.  
Akron, OH 44319

Amy Baker: [amy@fmbgov.com](mailto:amy@fmbgov.com)  
Nancy Stuparich: [nstuparich@voselaw.com](mailto:nstuparich@voselaw.com)  
Michael Hauserman: [Michael.hauserman@fmbgov.com](mailto:Michael.hauserman@fmbgov.com)

I certify this document to be a true and correct copy of the original on file in Town Hall, Fort Myers Beach, State of Florida, County of Lee.

BY:   
Amy Baker (Jan 8, 2026 15:15:52 EST)  
Town Clerk and Clerk to the Special Magistrate

DATED: Jan 8, 2026

APPEAL: An aggrieved party may appeal an Order of the Special Magistrate of the Town of Fort Myers Beach to the Lee County Circuit Court. The appeal shall be limited to appellate review of the record created before the Special Magistrate. An appeal shall be filed within thirty (30) days of the execution of the Order to be appealed.

PAYMENT OF ADMINISTRATIVE COSTS, LIENS OR FINES: Checks should be made payable to "Town of Fort Myers Beach," include the case number and mail to:

Town of Fort Myers Beach  
Attention: Code Enforcement  
6231 Estero Boulevard  
Fort Myers Beach, FL 33931

# STATUS HEARING / EXHIBIT A

- Special Magistrate Orders
- Affidavit of Non-Compliance
- Affidavit of Compliance

CODE COMPLIANCE SPECIAL MAGISTRATE  
THE TOWN OF FORT MYERS BEACH, FLORIDA

TOWN OF FORT MYERS BEACH,  
a Florida municipal corporation,

FMB CASE NO. 2025019

Petitioner,

vs.

JOHN K. DANIELS,

Respondent.

---

CODE ENFORCEMENT VIOLATION FINDINGS OF FACT,  
CONCLUSIONS OF LAW, AND ORDER

THIS CAUSE came before the undersigned Administrative Law Judge, John G. Van Laningham, serving as the Special Magistrate for the Town of Fort Myers Beach (“Special Magistrate”), on October 29, 2025. The Respondent’s son, Joe Daniels, was present at the hearing and authorized to speak on behalf of the Respondent. The Town of Fort Myers Beach (the “Town”) was represented by its Code Enforcement Officers and the Town Attorney. The purpose of the hearing was to adjudicate the Town’s Notice of Violation and Notice of Code Enforcement Hearing, dated September 24, 2025 (“NOV”). After reviewing sworn testimony from the parties and supporting evidence in the record, including photographs, the Special Magistrate makes the following Findings of Fact, Conclusions of Law and Order:

**A. FINDINGS OF FACT**

1. According to the Lee County Property Appraiser records, the Respondent is the owner of the real property located at 250/252 Bahia Via, Fort Myers Beach, Florida (the “Subject Property”).
2. On September 24, 2025, Code Enforcement Officer Thomas Yozzo observed a violation on the Subject Property for the “Demolition, Construction and or repair of a structure in disrepair without obtaining required permits. Including but not limited to

siding, windows, roofing, interior remodel and full or partial demolition defined in Section 6-441 of the FMB Code of Ordinances...”

3. Respondent’s representative testified that Respondent does not contest the violation.

### **B. CONCLUSIONS OF LAW**

1. Respondent received proper notice of the hearing and an opportunity to correct the violation prior to the October 29, 2025, hearing.
2. Respondent violated Section 6-441 of the FMB Code of Ordinances by constructing or repairing the Subject Property without obtaining required permits.
3. The Town’s enforcement efforts reflect its responsibility to protect the residents in the Town from faulty and unsafe construction and repair of structures by requiring building permits.

### **C. ORDER**

Based on the foregoing, it is hereby ORDERED as follows:

**Compliance Deadline and Review Hearing:** Respondent is in violation of Section 6-441 of the Town of Fort Myers Beach Code of Ordinances. Respondent must obtain the needed permits by December 3, 2025 (“Compliance Date”). A status review hearing is scheduled for January 6, 2026, to evaluate compliance progress. The Special Magistrate will consider compliance steps taken in deciding whether to impose or defer fines at the hearing on January 6, 2026.

**Daily Fine:** A fine of \$250.00 per day will be imposed for each day the violation continues beyond the Compliance Date, unless deferred at the status review hearing based upon the circumstances then existing.

**Special Magistrate Administrative Fee:** Pursuant to section 162.07(2), Florida Statutes, Respondent shall pay \$250.00 to cover the costs associated with this enforcement action.

This Order may be appealed by any aggrieved party to the Circuit Court of Lee County no later than 30 days from the date of this Order. Failure to timely file a written Notice of Appeal will waive the right of appeal.

DONE AND ORDERED this 12th day of November, 2025.

  
\_\_\_\_\_  
John G. Van Laningham,  
Special Magistrate

**CERTIFICATE OF SERVICE**

I, the undersigned, hereby certify that a true and correct copy of this Order has been furnished by U.S. mail on this 13th day of November 2025, to:

John K. Daniels  
250/252 Bahia Via,  
Fort Myers Beach , Fl 33931

John K. Daniels  
134 West Nimisila Rd.  
Akron, OH 44319

Amy Baker: [amy@fmbgov.com](mailto:amy@fmbgov.com)  
Nancy Stuparich: [nstuparich@voselaw.com](mailto:nstuparich@voselaw.com)  
Thomas Yozzo: [tyozzo@fmbgov.com](mailto:tyozzo@fmbgov.com)  
Michael Houserman: [Michael.houserman@fmbgov.com](mailto:Michael.houserman@fmbgov.com)

I certify this document to be a true and correct copy of the original on file in Town Hall, Fort Myers Beach, State of Florida, County of Lee.

By:   
Amy Baker (Nov 13, 2025 14:18:30 EST)  
Town Clerk and Clerk to Special Magistrate

Dated: Nov 13, 2025

**APPEAL:** An aggrieved party may appeal an Order of the Special Magistrate of the Town of Fort Myers Beach to the Lee County Circuit Court. The appeal shall be limited to appellate review of the record created before the Special Magistrate. An appeal shall be filed within thirty (30) days of the execution of the Order to be appealed.

**PAYMENT OF ADMINISTRATIVE COSTS, LIENS OR FINES:** Checks should be made payable to "Town of Fort Myers Beach," include the case number and mail to:

Town of Fort Myers Beach  
Attention: Code Enforcement  
6231 Estero Boulevard  
Fort Myers Beach, FL 33931



TOWN OF FORT MYERS BEACH,

Petitioner,

vs.

John K Daniels  
134 West Nimisila Rd  
Akron, OH 44319

Respondent,

FMB Case Number:	20250819
Certified Mail:	N/A
Regular Mail:	N/A

Site Address: 250/252 Bahia Via, Fort Myers Beach, FL, 33931  
Parcel Strap No. 34-46-24-W4-00029.0000

**AFFIDAVIT OF NON-COMPLIANCE**

STATE OF FLORIDA)

COUNTY OF LEE)

BEFORE ME, the undersigned authority personally appeared **Michael J Hauserman** who is the Code Enforcement Manager for the Town of Fort Myers Beach, who was sworn and under oath, deposes and says the following regarding Code Enforcement Case **#20250819**.

1. That on **10/29/2025**, the Special Magistrate held a public hearing and issued an order in the above styled manner.
2. That, pursuant to said order, the Respondent was to have taken certain corrective action by on or before **12/03/2025**.
3. That a re-inspection was performed on **12/18/2025**. That the re-inspection revealed that the corrective action ordered by the Special Magistrate has not been taken.



- 4. I have attached permit records of the subject property and photos taken on **12/18/2025**, which I personally printed, and which fairly represent the condition of the property at the time of my inspection.
  
- 5. The Town of Fort Myers Beach hereby has requested a hearing before the Special Magistrate and that an order be issued affording the appropriate relief, including an order to access any and all fines and administrative fees imposed by the Special Magistrate.

Under penalties of perjury, I declare that I have read the foregoing affidavit and that the facts stated in it are true and to the best of my knowledge and belief comply with Section 2-429 of the Town Land Development Code and Section 162.12, Florida Statutes.

X *[Signature]*  
 Signature of Affiant

**STATE OF FLORIDA  
 COUNTY OF LEE**

The foregoing instrument was sworn to, subscribed and acknowledged before me by means of either  personal presence or  online notarization this 18 day of December 2025, by Michael J Hauserman. He  is personally known to me or  has produced \_\_\_\_\_ as identification.



*Tracie Raski*  
 Notary Public, State of Florida  
 Print Name: Tracie Raski  
 My Commission Expires: 2/3/2029



Date: 11/25/2025

Contractor: Owner-Builder John Daniels

RE: 236619/250/252 BAHIA VIA/ Replace front door, add 2X4 framing, install plywood outside, install drywall inside, paint, install trim, paint trim, insulate wall where side light was, stucco

The drawings submitted for the referenced project have been reviewed following the 8<sup>th</sup> Edition (2023) Florida Building Codes, Florida Statutes (F.S), and the Town of Fort Myers Beach Land Development Code. For the reasons listed below, we cannot approve your application at this time.

---

***Please provide the Rejection Letter and a Cover Letter showing where each corrected item can be found.***

**1<sup>st</sup> Rejection Letter – Flood**

**Kelli Defedericis, [Kelli.Defedericis@fmbgov.com](mailto:Kelli.Defedericis@fmbgov.com) (Flood Reviewer)**

#### **Rejection comments**

**In further review property and flood insurance policy payout from IAN there seems to be a discrepancy with the cost breakdown provided and the policy payout.**

**Please email me the policy payout so I may review and confirm the proposed work is consistent with the NFIP policy payout.**

**Kdefedericis@fmbgov.com  
Kelli – Floodplain**

#### **PLEASE NOTE:**

- **Mailed in or paper plans will not be accepted.**
- **Submit all corrections together at one time with an appropriate response/ cover letter showing where each corrected item can be found to [resubmittal@fmbgov.com](mailto:resubmittal@fmbgov.com).**
- **Please note that no other reviews will be done until the **Zoning Review** is approved.**
- **Resubmittals will not be processed unless all review comments are addressed.**

**Please refer to the **Permit Portal** to access a copy of this rejection letter.**

**Sincerely,**

**Town of Fort Myers Beach Building Services and Community Development Departments.**



Dec 18, 2025 10:33:08 AM



Dec 18, 2025 10:33:55 AM



Dec 18, 2025 10:33:25 AM



TOWN OF FORT MYERS BEACH,

Petitioner,

vs.

<b>FMB Case Number:</b>	<b>20250819</b>
<b>Certified Mail:</b>	<b>N/A</b>
<b>Regular Mail:</b>	<b>N/A</b>

John K Daniels  
134 West Nimislia Rd  
Akron, OH 44319

Respondent,

Site Address: **250/252 Bahia Via**, Fort Myers Beach, FL, 33931  
Parcel Strap No. **34-46-24-W4-00029.0000**

**AFFIDAVIT OF COMPLIANCE**

STATE OF FLORIDA)

COUNTY OF LEE)

BEFORE ME, the undersigned authority personally appeared **Michael J Hauserman** who is the Code Enforcement Manager for the Town of Fort Myers Beach, who was sworn and under oath, deposes and says the following regarding Code Enforcement Case **#20250819**.

1. That on **10/29/2025**, a notice of violation was issued in the above styled manner.
2. That, pursuant to said notice, the Respondent was to have taken certain corrective action.
3. That a re-inspection was performed on **01/12/2026**. That the re-inspection revealed that the corrective action ordered by the notice of violation has been taken.
4. I have attached proof of compliance as evidence by a building permit.



Under penalties of perjury, I declare that I have read the foregoing affidavit and that the facts stated in it are true and to the best of my knowledge and belief comply with Section 2-429 of the Town Land Development Code and Section 162.12, Florida Statutes.

x [Signature]  
Signature of Affiant

STATE OF FLORIDA  
COUNTY OF LEE

The foregoing instrument was sworn to, subscribed and acknowledged before me by means of either  personal presence or  online notarization this 12 day of FEBRUARY, 2026, by Michael J Hauserman. He  is personally known to me or  has produced \_\_\_\_\_ as identification.

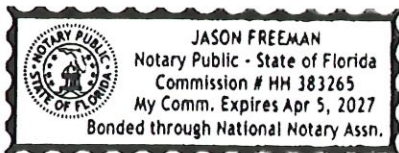

[Notary Seal]

[Signature]  
Notary Public, State of Florida  
Print Name: JASON FREEMAN  
My Commission Expires: APRIL 5, 2027



**Permit #:** 236619

**Permit Date:** 12/04/23

**Permit Type:**

**Permit Type:** Residential

**Sub Type:** Remodel

**Type of Construction:** N/A

**Type of Occupancy / Use:** Residential

**Contractor Business Name/Applicant:** Owner-Builder

**Contact Name:** John Daniels

**Contractor/Applicant Email:** Jack\_Daniels@Kandel.com

**Contractor/Applicant Phone #:** 3303527464

**Property Owner's Email:** Jack\_Daniels@Kandel.com

**Current Use:** r

**Proposed Use:** r

**Scope of Work:** Replace front door, add 2X4 framing, install plywood outside, install drywall inside, paint, install trim, paint trim, insulate wall where side light was, stucco

**Project Cost:** 2435

**Gross Square Feet:** 10

**Issued Date:** 01/12/2024

**Expiration Date:** 04/16/2026

**Final Date:**

**Closed Date:**

**Repair Damage Due To:**

**Storm Damage:**

**Floodplain:**

**Status:** ISSUED

**Assigned To:**

**Property**

Parcel #	Address	Legal Description	Owner Name	Owner Phone	Zoning
344624W4000290000	250/252 BAHIA VIA	LOT 18 BLK A SANTINI CROSS UNREC PLAT BEG SELY COR BLK I MC PHIE PK #2 SELY	DANIELS JOHN K		RS-1

## Contractors

Contractor	Primary Contact	Phone	Address	Contractor Type	License	License #
John K Daniels	John K Daniels		250 Bahia Via	Owner Builder		

## Plan Reviews

Date	Review Type	Description	Assigned To	Review Status
12/04/2023	Notice of Commencement		Misty Alexander	NOT REQUIRED
12/04/2023	Reviews completed- Notification sent		*	
01/21/2026	Review Flood		Joe Specht	REVIEWED FOR COMPLIANCE
12/04/2023	Review Res. Plan review		Joe Specht	REVIEWED FOR COMPLIANCE
12/04/2023	Review FMB Application	Need residential application as this scope of work is more than just a door replacement *Received 12/4/23	Misty Alexander	DONE
12/04/2023	Owner Builder AFFIDAVIT		Misty Alexander	DONE
10/17/2025	Completion Permit Requested	Request to reissue the permit.	Jerlydene Naidoo	DONE
10/22/2025	Revision Submitted (Plan Review)	Work Below the 50% threshold structure value \$434,453.  In further review property and flood insurance policy payout from IAN there seems to be a discrepancy with the cost breakdown provided and the policy payout.	Kelli DeFedericis	APPROVED
10/22/2025	Revision Submitted (Flood)	Please email me the policy payout so I may review and confirm the proposed work is consistent with the NFIP policy payout.  Kdefedericis@fmbgov.com Kelli - Floodplain	Kelli DeFedericis	RESUBMITTAL REQUIRED
10/22/2025	Plumb. Sub Permit Req	REV 1 - Additional scope of work. - update-plbg app received. Owner/Builder	Madeleine Tirado	DONE
10/22/2025	Rejection Letter Sent	1st revised plan rejection letter	Janavae Bowie	DONE
10/24/2025	Resubmitted (Plan Review)	plan resub 1	Joe Specht	REVIEWED FOR COMPLIANCE
10/24/2025	Notice of Commencement	Recorded NOC	Madeleine Tirado	DONE
11/10/2025	Rejection Letter Sent	1st flood rejection letter sent	Janavae Bowie	DONE
01/12/2026	Revision Submitted (Flood)	structure value 1,011,308 cost of work 129,462	Kelli DeFedericis	APPROVED

## Fees

Fee	Description	Notes	Amount
RES – New One & Two Family Dwelling Construction, Remodel, Addition, Carport, Stand Alone Garage (2024)	<p>*** IMPACT FEES NOT INCLUDED ***</p> <p>Enter Commercial Calculation if over 6,500 sqft.</p> <p>Includes:</p> <ul style="list-style-type: none"> <li>Application Processing Fee</li> <li>Building Plan Review and Inspection</li> <li>Environmental Review</li> <li>Flood Review</li> <li>Stormwater Review</li> <li>Zoning Review</li> <li>Electrical Review and Electrical Inspection</li> <li>Mechanical Review and Mechanical Inspection</li> <li>Plumbing Review and Plumbing Inspection</li> </ul>		\$1,860.00

Roof  
Sewer Connection

* MISC- DBPR & DCA Admin Fees	\$46.50
*MISC – Reissuance of Expired Permit: Residential (not including Code Enforcement Fees) (2024)	\$300.00
*MISC – Plan Revision (after issuance of permit) (2024)	\$60.00
<b>Total</b>	<b>\$2,266.50</b>

**Attached Letters**

Date	Letter	Description
06/12/2024	<a href="#">30 Day Expiration Notice</a>	
01/12/2024	<a href="#">Building Permit</a>	

**Payments**

Date	Paid By	Description	Payment Type	Accepted By	Amount
01/10/2024	John Daniels	Invoice: 783775			\$1,906.50
10/17/2025	Joseph Richard Daniels	1431846			\$300.00
10/23/2025	Joseph Daniels	1439262			\$60.00
<b>Outstanding Balance</b>					<b>\$0.00</b>

**Notes**

Date	Note	Created By:
10/22/2025	Need plumbing sub contractor application for additional scope of work added to existing permit-update Owner/builder plbg application received-Maddie	Madeleine Tirado

**Uploaded Files**

Date	File Name
01/12/2026	<a href="#">30231775-MULTI-FAMILY LESS THAN 10 Cost Card for 10231013.pdf</a>
01/12/2026	<a href="#">30231736-Updated Fema docs bahia via.pdf</a>
01/12/2026	<a href="#">30231691-Re_Permit #236619 FEMA Docs - Kelli DeFedericis - Outlook.pdf</a>
01/12/2026	<a href="#">30231580-Pre-storm Appraisal by Huntington.pdf</a>
11/25/2025	<a href="#">29702035-1st flood rejection letter 236619.pdf</a>
10/27/2025	<a href="#">29151546-#236619-Plbg signed subcontractor form.pdf</a>
10/24/2025	<a href="#">29040000-#236619-Recorded NOC.pdf</a>
10/24/2025	<a href="#">29034453-Rejection letter 1 response.pdf</a>
10/22/2025	<a href="#">28998270-1st revised plan rejection letter.pdf</a>
10/22/2025	<a href="#">28991840-#236619-Lower level print.pdf</a>
10/22/2025	<a href="#">28991826-#236619-250-252 Revisions form.pdf</a>
10/22/2025	<a href="#">28991806-#236619-Scope of work.pdf</a>
10/22/2025	<a href="#">28991799-#236619-250-252 owner builder disclosure.pdf</a>
10/22/2025	<a href="#">28991797-#236619-Signed cost form.pdf</a>
10/17/2025	<a href="#">28932631-20251017125335435.pdf</a>
01/12/2024	<a href="#">18175456-JOBSITE COPY 236619.pdf</a>
12/04/2023	<a href="#">17660717-Residential Application.pdf</a>
11/30/2023	<a href="#">38effe02e5efeb2e9a11c10f6465eccf_full_door_permit_application.pdf</a>

CODE COMPLIANCE SPECIAL MAGISTRATE  
THE TOWN OF FORT MYERS BEACH, FLORIDA

TOWN OF FORT MYERS BEACH,  
a Florida municipal corporation,

Petitioner,

vs.

FMB Case No. 20250853

ADRIENNE TURNER

Respondent.

\_\_\_\_\_ /

ORDER OF CONTINUANCE

The undersigned hereby gives notice that the Honorable Judge John G. Van Laningham continued a hearing in the above case at the Fort Myers Beach Council Chambers from Tuesday, February 3, 2026. The continued hearing will be held on **Tuesday, March 3, 2026 at 9:00 a.m.** at the Town of Fort Myers Beach Town Hall located at 6231 Estero Boulevard, Fort Myers Beach, Lee County, Florida.

Ordered this 16th day of January 2026.

  
\_\_\_\_\_  
John G. Van Laningham,  
Special Magistrate

**CERTIFICATE OF SERVICE**

I, the undersigned, hereby certify that true and correct copy of the Order was sent by U.S. Mail on the 16 day of January 2026, to:

Adrienne Turner  
17226 Willow Wood Dr  
Strongsville, OH 44136

Nancy Stuparich: [nstuparich@voselaw.com](mailto:nstuparich@voselaw.com)  
Michael Hauserman: [Michael.hauserman@fmbgov.com](mailto:Michael.hauserman@fmbgov.com)  
Amy Baker: [amy@fmbgov.com](mailto:amy@fmbgov.com)

I certify this document to be a true and correct copy of the original on file in Town Hall, Fort Myers Beach, State of Florida, County of Lee.

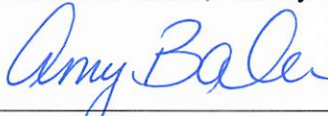
BY:   
Town Clerk and Clerk to the Special Magistrate

Dated: January 16, 2026

APPEAL: An aggrieved party may appeal an Order of the Special Magistrate of the Town of Fort Myers Beach to the Lee County Circuit Court. The appeal shall be limited to appellate review of the record created before the Special Magistrate. An appeal shall be filed within thirty (30) days of the execution of the Order to be appealed.

PAYMENT OF ADMINISTRATIVE COSTS, LIENS OR FINES: Checks should be made payable to "Town of Fort Myers Beach," include the case number and mail to:

Town of Fort Myers Beach  
Attention: Code Enforcement  
6231 Estero Boulevard  
Fort Myers Beach, FL 33931

CODE COMPLIANCE SPECIAL MAGISTRATE  
THE TOWN OF FORT MYERS BEACH, FLORIDA

TOWN OF FORT MYERS BEACH,  
a Florida municipal corporation

Petitioner,  
vs.

FMB CASE NO. 20250853

ADRIENNE TURNER,

Respondent.

---

CODE ENFORCEMENT VIOLATION FINDINGS OF FACT,  
CONCLUSIONS OF LAW, AND ORDER

THIS CAUSE came before the undersigned Administrative Law Judge, John G. Van Laningham, serving as the Special Magistrate for the Town of Fort Myers Beach (“Special Magistrate”), on October 29, 2025. The Respondent was present at the hearing. The Town of Fort Myers Beach (the “Town”) was represented by its Code Enforcement Officers and the Town Attorney. The purpose of the hearing was to adjudicate the Town’s Notice of Violation and Notice of Code Enforcement Hearing, dated September 30, 2025 (“NOV”). After reviewing sworn testimony from the parties and supporting evidence in the record, including photographs, the Special Magistrate makes the following Findings of Fact, Conclusions of Law, and Order:

**A. FINDINGS OF FACT**

1. According to the Lee County Property Appraiser records, the Respondent is the owner of the real property located at 12 Fairview Boulevard, Fort Myers Beach, Florida (the “Subject Property”).
2. On September 30, 2025, Code Enforcement Officer Thomas Yozzo observed a violation on the Subject Property for the “Demolition, Construction and or repair of a structure in disrepair without obtaining required permits. Including but not limited to siding, windows, roofing, interior remodel and full or partial demolition defined in Section 6-441 of the FMB Code of Ordinances...”
3. Respondent testified that Respondent she does not contest the violation.

**B. CONCLUSIONS OF LAW**

1. Respondent received proper notice of the hearing and an opportunity to correct

the violation prior to the October 29, 2025 hearing.

2. Respondent violated Section 6-441 of the FMB Code of Ordinances by constructing or repairing the Subject Property without first obtaining required permits.
3. The Town's enforcement efforts reflect its responsibility to protect the residents in the Town from faulty and unsafe construction and repair of structures by requiring building permits.

### C. ORDER

Based on the foregoing, it is hereby ORDERED as follows:

**Compliance Deadline and Review Hearing:** Respondent is in violation of Section 6-441 of the Town of Fort Myers Beach Code of Ordinances. Respondent must obtain the needed permits by December 3, 2025 ("Compliance Date"). A status review hearing is scheduled for January 6, 2026, to evaluate compliance progress. The Special Magistrate will consider compliance steps taken in deciding whether to impose or defer fines at the hearing on January 6, 2026.

**Daily Fine:** A fine of \$250.00 per day will be imposed for each day the violation continues beyond the Compliance Date, unless deferred at the status review hearing based upon the circumstances then existing.

**Special Magistrate Administrative Fee:** Pursuant to section 162.07(2), Florida Statutes, Respondent shall pay \$250.00 to cover the costs associated with this enforcement action.

This Order may be appealed by any aggrieved party to the Circuit Court of Lee County no later than 30 days from the date of this Order. Failure to timely file a written Notice of Appeal will waive the right of appeal.

DONE AND ORDERED this 12th day of November, 2025.

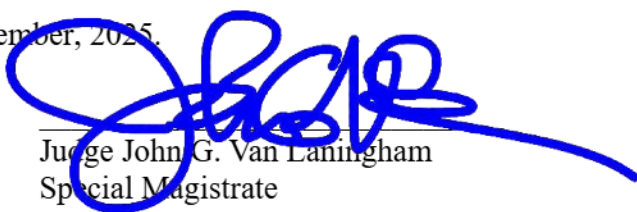
  
\_\_\_\_\_  
Judge John G. Van Laningham  
Special Magistrate

CERTIFICATE OF SERVICE

I, the undersigned, hereby certify that a true and correct copy of this Order has been furnished by U.S. mail on this 13th day of November, 2025 to:

Adrienne Turner  
17226 Willow Wood Rd  
Strongsville, OH 44136

Amy Baker: [amy@fmbgov.com](mailto:amy@fmbgov.com)  
Nancy Stuparich: [nstuparich@voselaw.com](mailto:nstuparich@voselaw.com)  
Thomas Yozzo: [tyozzo@fmbgov.com](mailto:tyozzo@fmbgov.com)  
Michael Houserman: [Michael.houserman@fmbgov.com](mailto:Michael.houserman@fmbgov.com)

I certify this document to be a true and correct copy of the original on file in Town Hall, Fort Myers Beach, State of Florida, County of Lee.

BY:   
Amy Baker (Nov 13, 2025 13:25:23 EST)  
Town Clerk and Clerk to the Special Magistrate

DATED: Nov 13, 2025

APPEAL: An aggrieved party may appeal an Order of the Special Magistrate of the Town of Fort Myers Beach to the Lee County Circuit Court. The appeal shall be limited to appellate review of the record created before the Special Magistrate. An appeal shall be filed within thirty (30) days of the execution of the Order to be appealed.

PAYMENT OF ADMINISTRATIVE COSTS, LIENS OR FINES: Checks should be made payable to "Town of Fort Myers Beach," include the case number and mail to:

Town of Fort Myers Beach  
Attention: Code Enforcement  
6231 Estero Boulevard  
Fort Myers Beach, FL 33931

# STATUS HEARING EXHIBIT A

- Special Magistrate Order
- Affidavit of Compliance / Non-Compliance
- Inspection photographs/permit evidence



TOWN OF FORT MYERS BEACH,

Petitioner,

vs.

<b>FMB Case Number:</b>	<b>20250853</b>
<b>Certified Mail:</b>	<b>N/A</b>
<b>Regular Mail:</b>	<b>N/A</b>

Turner Adrienne  
17226 Willow Wood Dr  
Strongsville, OH 44136

Respondent,

Site Address: **12 Fairview Blvd**, Fort Myers Beach, FL, 33931  
Parcel Strap No. 34-46-24-W4-00400.0060

**AFFIDAVIT OF COMPLIANCE**

STATE OF FLORIDA)

COUNTY OF LEE)

BEFORE ME, the undersigned authority personally appeared **Michael J Hauserman** who is the Code Enforcement Manager for the Town of Fort Myers Beach, who was sworn and under oath, deposes and says the following regarding Code Enforcement Case **#20250853**.

1. That on **10/29/2025**, the Special Magistrate held a public hearing and issued an order in the above styled manner.
2. That, pursuant to said order, the Respondent was to have taken certain corrective action by on or before **12/03/2025**.
3. That a re-inspection was performed on **12/12/2025**. That the re-inspection revealed that the corrective action ordered by the Special Magistrate has been taken.
4. I have attached permit records of the subject property, which I personally printed, and which fairly represent the condition of the property at the time of my inspection. .

**FORT MYERS BEACH ESTERO ISLAND**

**P. 239-765-0202 | 2731 Oak Street, Fort Myers Beach, FL 33931**



- 5. The Town of Fort Myers Beach hereby has requested a hearing before the Special Magistrate and that an order be issued affording the appropriate relief, including an order to access any and all fines and administrative fees imposed by the Special Magistrate.

Under penalties of perjury, I declare that I have read the foregoing affidavit and that the facts stated in it are true and to the best of my knowledge and belief comply with Section 2-429 of the Town Land Development Code and Section 162.12, Florida Statutes.

X   
Signature of Affiant

STATE OF FLORIDA  
COUNTY OF LEE

The foregoing instrument was sworn to, subscribed and acknowledged before me by means of either  personal presence or  online notarization this 12 day of December, 2025, by Michael J Hauserman. He  is personally known to me or  has produced \_\_\_\_\_ as identification.

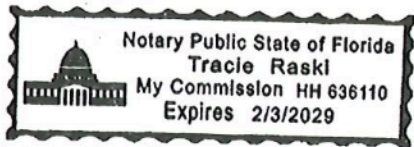

[Notary Seal]

  
Notary Public, State of Florida  
Print Name: Tracie Raski  
My Commission Expires: 2/3/2029

FORT MYERS BEACH ESTERO ISLAND



Reviewed for Compliance

PERMIT 252074

Town of Fort Myers Beach
Building Department

2525 Estero Blvd Fort Myers Beach, Florida 33931
Phone: (239) 765-0202 Fax: (239)765-0909

Approval Letter

BUILD RESPONSIBLY!
GO TO:
https://www.fortmyersbeachfl.gov/
DocumentCenter/View/16329/BUILD-RESPONSIBLY

Date: 12/12/25

Permit #: 252074

Address: 12 FAIRVIEW BLVD FORT MYERS BEACH, FL 33931

Applicant: Owner Builder

Scope of Work: Permitting for IAN

Table with 3 columns: Review Type, Reviewer, Review Status. Rows include Zoning Review, Flood Review (STEVE POPOSKI), Plan Review (PETER HAIGIS), Stormwater Review, Environmental Review, Public Works Review, and Beach Water Review.

Permit Conditions:

Erosion Control and Construction Site Maintenance
All new construction, alterations, or renovations shall comply with the Town of Fort Myers Beach Land Development Code and Florida Building and Stormwater Regulations. Prior to any land-disturbing activity, the permit holder shall install and maintain erosion and sediment controls (e.g., silt fencing, inlet protection) and ensure proper onsite waste management (dumpsters, portable toilets). Controls must remain in place until the site is permanently stabilized. Projects disturbing one acre or more must implement a stormwater Pollution Prevention Plan (SWPPP) in accordance with Florida DEP and NPDES requirements. Noncompliance may result in stop-work orders or code enforcement action.



# Qualifier Acknowledgement

This page is required for ALL Building Permit Applications

## ACKNOWLEDGEMENT OF TOWN OF FORT MYERS BEACH REGULATIONS BY THE QUALIFIER

**NOTICE OF ADDITIONAL RESTRICTIONS:** In addition to the requirements of this permit, there may be additional restrictions applicable to this property that maybe found in the public records of this County, and there may be additional permits required from other governmental entities such as the Water Management District, State agencies, or Federal agencies. I acknowledge that any demolition or renovation of an existing structure must comply with Florida Statutes s. 469.003, Florida Building Code, and any other relevant regulations, including state and federal law. I understand that I am responsible for notifying the Department of Environmental Protection in advance of any intentions to remove asbestos, when applicable, in accordance with state and federal law.

**WARNING OF WORK IN THE COUNTY RIGHT-OF-WAYS:** This permit does not authorize construction or installation of any structure or utility, above or below ground, within any right of way or easement reserved for access, drainage or utility purposes. This restriction specifically prohibits fencing, sprinkler systems, landscaping other than sod, signs, water, sewer, cable and drainage work therein. If such improvements are necessary, a separate permit for that purpose must be obtained from the Building Department.

**INSPECTIONS:** This permit is void if the first inspection is not made within six (6) months from the date issued or if no inspection has been made for a period of six (6) months from the most recently passed inspection. The permit is void if the zoning classification is violated. Applicant agrees to comply with the sanitary regulations and understands that the proposed structure may not be used or occupied until an approved certificate of occupancy is issued. Applicant further understands that failure to obtain permit or misrepresentation of the improvements is a misdemeanor and upon conviction, applicant can be punished as provided by the law. Failure to comply with the mechanics lien law can result in the property owner paying twice for improvements

**NOTICE OF CLEARING RESTRICTIONS:** Issuance of a Demolition Permit for a structure does not authorize removal of vegetation beyond the footprint of the structure. A Demo Permit is not a clearing permit.

**WORK IN THE SPECIAL FLOOD HAZARD AREA:** Be advised that Substantial Damage/Substantial Improvement requirements will apply to structures located in the Special Flood Hazard Area with Finished Floor Elevations below the Base Flood Elevation.

**CERTIFICATION:** Application is hereby made to obtain a permit to do the work and installations as indicated. I, THE QUALIFIER, certify that I have not performed any work or installation prior to the issuance of a permit and that all work will be performed to meet the standards of all laws regulating construction in this jurisdiction. The permit or application fee may have additional fees imposed for failing to obtain permits prior to commencement of construction. The permit application or approved permit expires if work is not commenced within 180 days from the date of issuance. I, THE QUALIFIER understand that the structure cannot be used or occupied until a certificate of occupancy is issued. By signing this permit application, I, THE QUALIFIER, agree that I have been retained by the property owner to provide contracting services for the trade for which I am listed. Furthermore, it is my responsibility to notify the Building Plan Review and Inspection Division should I no longer be THE QUALIFIER responsible for providing said contracting services. I, THE QUALIFIER, agree that I understand the review and issuing of this permit does not exempt me from complying with all County Codes and Ordinances.

**NOTICE OF COMMENCEMENT INFORMATION** Per Florida Statutes 713.135 a Notice of Commencement (NOC) is required for construction of improvements totaling more than

\$2,500, with certain exceptions. For A/C Repairs or Replacements a notice of commencement is required for improvements more than or equal to \$15,000. The applicant shall file with the issuing authority prior to the first inspection either a certified copy of the recorded NOC or a notarized statement that the NOC has been filed for recording, along with a copy thereof. In order to comply with the state requirement, permits will be placed in inspection hold until proof of the NOC is filed with the building permitting and inspection department. The issuing authority shall not perform or approve subsequent inspections until the applicant files by mail, facsimile, hand delivery, email or any other means such as certified copy with the issuing authority.

**WARNING TO OWNER: YOUR FAILURE TO RECORD A NOTICE OF COMMENCEMENT MAY RESULT IN YOUR PAYING TWICE FOR IMPROVEMENTS TO YOUR PROPERTY. A NOTICE OF COMMENCEMENT MUST BE RECORDED AND POSTED ON THE JOB SITE BEFORE THE FIRST INSPECTION. IF YOU INTEND TO OBTAIN FINANCING, CONSULT WITH YOUR LENDER OR AN ATTORNEY BEFORE RECORDING YOUR NOTICE OF COMMENCEMENT.**

Job Street Address: 12 Fairview Blvd Fort Myers Beach Fl 33931

I, Adrienne Turner (Qualifier), hereby certify that all answers to the questions in this registration and any supplementary information attached to and made part of this registration is honest and true.

Adrienne Turner  
Typed or printed name of Qualifier

Adrienne Turner  
Signature of Qualifier

STATE OF Ohio COUNTY OF Cuyahoga

The foregoing instrument was certified and subscribed before me by means of  physical presence OR  online notarization, this 10<sup>th</sup> day of Oct, 2025, by

Adrienne Turner, who is personally known to me OR  who has produced Ohio DL as identification.

[Signature]  
Notary Public Signature



KOURTNEY THOMAS  
NOTARY PUBLIC - OHIO  
MY COMMISSION EXPIRES  
03-11-29  
(seal)



Project: Permit 252074  
 Location: 12 Fairview Blvd

Scope: INTERIOR REPAIRS HURRICANE REBUILD

A. Masonry B. Carpentry C. Roofing D. Insulation and Weather-strip E. Exterior Finish (eg. Stucco) F. Doors, Windows & Shutters G. Lumber Finish

IMPROVED VALUE must be entered on last page

Date: 10/22/2025

Cost Code	Detail Description	MATERIALS			LABOR			Total	Sub-CONTRACTOR ?
		Qty	Unit	Cost per Unit	Hours	Cost per Hour	Total		
D. Insulation and Weather-strip	Insulation R11 Fib-Foil	4.0	sheets	\$ 77.00	6.2	\$ 25.00	\$ 155.00	\$ 483.00	no
F. Doors, Windows & Shutters	Interior doors (no exterior doors or windows needed)	9.0	each	\$ 253.00	8.0	\$ 25.00	\$ 200.00	\$ 2,477.00	no
G. Lumber Finish	base trim 6" baseboard	288.0	ft	\$ 3.50	58.0	\$ 50.00	\$ 2,900.00	\$ 3,908.00	no
I. Drywall	Replaced drywall	40.0	sheets	\$ 22.60	35.0	\$ 25.00	\$ 875.00	\$ 1,779.00	no
J. Cabinets (built-in)	Cabinets	15.0	each	\$ 480.00	80.0	\$ 50.00	\$ 4,000.00	\$ 10,750.00	no
O. Electrical & Light Fixtures	replace lower outlets only	29.0	each	\$ 3.00	8.0	\$ 25.00	\$ 200.00	\$ 287.00	no
M. Plumbing	Water Heater	1.0	each	\$ 749.00	2.0	\$ 25.00	\$ 50.00	\$ 799.00	no
R. HVAC	fixtures	7.0	each	\$ 225.00	14.0	\$ 50.00	\$ 700.00	\$ 2,275.00	no
S. Paint	not replaced still running	0.0	0	\$ -	0.0	\$ -	\$ -	\$ -	no
T. Demolition & Removal	Primer/paint	20.0	each	\$ 55.00	60.0	\$ 25.00	\$ 1,500.00	\$ 2,600.00	no
U. Overhead & Profit	Mold medication cleaner AND dehumidifier	10.0	gallons	\$ 25.00	40.0	\$ 25.00	\$ 1,000.00	\$ 1,200.00	no
	clean and removal	1.0		\$ 586.00	1.0	\$ 1,197.00	\$ 1,197.00	\$ 1,783.00	no
				\$ 586.00		\$ -	\$ -	\$ -	





STATE OF FLORIDA  
**LEE COUNTY PROPERTY APPRAISER**  
MATTHEW H. CALDWELL



**Mailing Address:**  
P.O. Box 1546  
Fort Myers, Florida 33902-1546

**Physical Address:**  
2480 Thompson Street  
Fort Myers, Florida 33901-3074

**Telephone:** (239) 533-6100

**Website:** [www.leepa.org](http://www.leepa.org)

October 16, 2025

10231180

TURNER ADRIENNE  
17226 WILLOW WOOD DR  
STRONGSVILLE, OH 44136

**Re: 2022 Tax Roll Value & FEMA 50% Rule**

12 FAIRVIEW BLVD FORT MYERS BEACH 33931  
34-46-24-W4-00400.0060

In the chart below you will find the most recent values from the 2022 ad valorem tax roll. These values represent the Lee County Property Appraiser's determination of Just Value for ad valorem tax purposes.

	JUST VALUE
Total Value	\$586,753
Land Value	\$226,700
Land Extra Features Value	\$0
Building Value	\$300,276
Building Extra Features Value	\$59,777

Further, the FEMA 50% rule calls for the use of "market value" in determining "substantial improvement" and the Lee County Commission has adopted a definition of market value which includes "...or tax assessment value adjusted to approximate market value by a factor provided by the Property Appraiser...", and the "Building Value" listed above will likely meet the needs of most owners. Please note that these are allocated values, developed as of January 1, 2022, and they may not reflect the current value of your property. If you believe that our conclusions and methods are not useful for your purposes, I encourage you to consult an independent professional.

Please be advised that we are providing this information as a proactive courtesy and this letter serves as an official copy of our records for the parcel listed above as of the effective date of this letter. I hope this letter is helpful to you as you evaluate the process of recovering from the impacts of Hurricane Ian.

Sincerely,

Hon. Matthew H. Caldwell



Owner Acknowledgement

This page is required for ALL Building Permit Applications

ACKNOWLEDGEMENT OF TOWN OF FORT MYERS BEACH REGULATIONS BY OWNER OR AUTHORIZED AGENT OF OWNER

NOTICE OF ADDITIONAL RESTRICTIONS: In addition to the requirements of this permit, there may be additional restrictions applicable to this property that maybe found in the public records of this County, and there may be additional permits required from other governmental entities such as the Water Management District, State agencies, or Federal agencies. I acknowledge that any demolition or renovation of an existing structure must comply with Florida Statutes s. 469.003, Florida Building Code, and any other relevant regulations, including state and federal law. I understand that I am responsible for notifying the Department of Environmental Protection in advance of any intentions to remove asbestos, when applicable, in accordance with state and federal law.

WARNING OF WORK IN THE COUNTY RIGHT-OF-WAYS: This permit does not authorize construction or installation of any structure or utility, above or below ground, within any right of way or easement reserved for access, drainage or utility purposes. This restriction specifically prohibits fencing, sprinkler systems, landscaping other than sod, signs, water, sewer, cable and drainage work therein. If such improvements are necessary, a separate permit for that purpose must be obtained from the Building Department.

INSPECTIONS: This permit is void if the first inspection is not made within six (6) months from the date issued or if no inspection has been made for a period of six (6) months from the most recently passed inspection. The permit is void if the zoning classification is violated. Applicant agrees to comply with the sanitary regulations and understands that the proposed structure may not be used or occupied until an approved certificate of occupancy is issued. Applicant further understands that failure to obtain permit or misrepresentation of the improvements is a misdemeanor and upon conviction, applicant can be punished as provided by the law. Failure to comply with the mechanics lien law can result in the property owner paying twice for improvements

NOTICE OF CLEARING RESTRICTIONS: Issuance of a Demolition Permit for a structure does not authorize removal of vegetation beyond the footprint of the structure. A Demo Permit is not a clearing permit.

WORK IN THE SPECIAL FLOOD HAZARD AREA: Be advised that Substantial Damage/Substantial Improvement requirements will apply to structures located in the Special Flood Hazard Area with Finished Floor Elevations below the Base Flood Elevation.

CERTIFICATION: Application is hereby made to obtain a permit to do the work and installations as indicated. I, THE OWNER OR AUTHORIZED AGENT OF OWNER, certify that I have not performed any work or installation prior to the issuance of a permit and that all work will be performed to meet the standards of all laws regulating construction in this jurisdiction. The permit or application fee may have additional fees imposed for failing to obtain permits prior to commencement of construction. The permit application or approved permit expires if work is not commenced within 180 days from the date of issuance. I, THE OWNER OR AUTHORIZED AGENT OF OWNER understand that the structure cannot be used or occupied until a certificate of occupancy is issued. By signing this permit application, I, THE OWNER OR AUTHORIZED AGENT OF OWNER, agree that I have been retained by the property owner to provide contracting services for the trade for which I am listed. Furthermore, it is my responsibility to notify the Building Plan Review and Inspection Division should I no longer be THE OWNER OR AUTHORIZED AGENT OF OWNER responsible for providing said contracting services. I, THE OWNER OR AUTHORIZED AGENT OF OWNER, agree that I understand the review and issuing of this permit does not exempt me from complying with all State and local County Codes and Ordinances.

NOTICE OF COMMENCEMENT INFORMATION Per Florida Statutes 713.135 a Notice of Commencement (NOC) is required for construction of improvements totaling more than \$2,500, with certain exceptions. For A/C Repairs or Replacements a notice of commencement is required for improvements more than or equal to \$15,000. The applicant shall file with the issuing authority prior to the first inspection either a certified copy of the recorded NOC or a notarized statement that the NOC has been filed for recording, along with a copy thereof. In order to comply with the state requirement, permits will be placed in inspection hold until proof of the NOC is filed with the building permitting and inspection department. The issuing authority shall not perform or approve subsequent inspections until the applicant files by mail, facsimile, hand delivery, email or any other means such as certified copy with the issuing authority.

WARNING TO OWNER: YOUR FAILURE TO RECORD A NOTICE OF COMMENCEMENT MAY RESULT IN YOUR PAYING TWICE FOR IMPROVEMENTS TO YOUR PROPERTY. A NOTICE OF COMMENCEMENT MUST BE RECORDED AND POSTED ON THE JOB SITE BEFORE THE FIRST INSPECTION. IF YOU INTEND TO OBTAIN FINANCING, CONSULT WITH YOUR LENDER OR AN ATTORNEY BEFORE RECORDING YOUR NOTICE OF COMMENCEMENT.

Job Street Address: 12 Fairview Blvd

Signature of Property Owner

Adrienne Turner
Typed or printed name of Property Owner

STATE OF Ohio COUNTY OF Cuyahoga

The foregoing instrument was certified and subscribed before me by means of physical presence OR online notarization, this 10th day of Oct, 2025, by Adrienne Turner who is personally known to me OR who has produced Ohio DL as identification.

Notary Public Signature

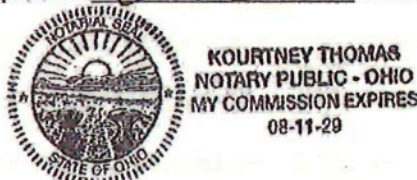

If An Owner Agent is Being Named, Please complete below

I, (Property Owner), hereby certify that is my authorized AUTHORIZED AGENT/representative of the property described herein. All answers to the questions in this registration and any supplementary information attached to and made part of this registration is honest and true.



**PLEASE NOTE:**

- Mailed in or paper plans will not be accepted.
- Submit all corrections together at one time with an appropriate response/ cover letter showing where each corrected item can be found to [resubmittal@fmbgov.com](mailto:resubmittal@fmbgov.com).
- Please note that no other reviews will be done until the **Zoning Review** is approved.
- Resubmittals will not be processed unless all review comments are addressed.

Please refer to the **Permit Portal** to access a copy of this rejection letter.

Sincerely,

Town of Fort Myers Beach Building Services and Community Development Departments.





**Substantial Damage  
Cost Estimate  
Worksheet**

Project: Permit 252074  
Location: 12 Fairview Blvd

Scope: INTERIOR REPAIRS HURRICANERE REBUILD

\* IMPROVED VALUE must be entered on last page

F. Doors, Windows & Shutters G. Lumber Finish

10/28/25  
10/22/2025 *revised*

Date

Reviewed for Compliance

PERMIT 252074

Cost Code Legend	Cost Code	Detail Description	MATERIALS			LABOR			Total	SUB-CONTRACTOR (2)	Y/N	
			Qty	Unit	Cost per Unit	Total	Hours	Cost per Hour				Total
D. Insulation and Weather-strip		Insulation R11 F-Foil	4.0	sheets	\$ 77.00	\$ 306.00		6.2	25.00	\$ 155.00	\$ 461.00	no
F. Doors, Windows & Shutters		interior doors (no exterior doors or windows needed)	9.0	each	\$ 253.00	\$ 2,277.00		8.0	25.00	\$ 200.00	\$ 2,477.00	no
G. Lumber Finish		base trim 6" baseboard	288.0	ft	\$ 3.50	\$ 1,008.00		58.0	50.00	\$ 2,900.00	\$ 3,908.00	no
		Replaced drywall	40.0	sheets	\$ 22.60	\$ 904.00		35.0	25.00	\$ 875.00	\$ 1,779.00	no
I. Drywall		Cabinets	15.0	each	\$ 450.00	\$ 6,750.00		80.0	50.00	\$ 4,000.00	\$ 10,750.00	no
J. Cabinets (built-in)		replace lower outlets only	29.0	each	\$ 3.00	\$ 87.00		8.0	25.00	\$ 200.00	\$ 287.00	no
O. Electrical & Light Fixtures		Water Heater	1.0	each	\$ 749.00	\$ 749.00		2.0	25.00	\$ 50.00	\$ 799.00	no
G. Electrical & Light Fixtures		fixtures	7.0	each	\$ 225.00	\$ 1,575.00		14.0	50.00	\$ 700.00	\$ 2,275.00	no
M. Plumbing		not replaced still running	0.0	0	\$ -	\$ -		0.0	-	\$ -	\$ -	no
R. HVAC		Primer/paint	20.0	each	\$ 55.00	\$ 1,100.00		60.0	25.00	\$ 1,500.00	\$ 2,600.00	no
S. Paint		Mold mediation cleaner AND dehumidifier	10.0	gallons	\$ 26.00	\$ 260.00		40.0	25.00	\$ 1,000.00	\$ 1,260.00	no
T. Demolition & Removal		clean and removal					240.0		30.00	\$ 7,200.00	\$ 7,200.00	no
T. Demolition & Removal		garage door	1.0	each	\$ 586.00	\$ 586.00		1.0	1,197.00	\$ 1,197.00	\$ 1,783.00	no
U. Overhead & Profit			1.0	each	\$ 2,500.00	\$ 2,500.00		6.0	35.00	\$ 210.00	\$ 2,710.00	no
F. Doors, Windows & Shutters												



STATE OF FLORIDA  
**LEE COUNTY PROPERTY APPRAISER**  
MATTHEW H. CALDWELL



Mailing Address:  
P.O. Box 1546  
Fort Myers, Florida 33902-1546

Physical Address:  
2480 Thompson Street  
Fort Myers, Florida 33901-3074

Telephone: (239) 533-6100

Website: [www.leepa.org](http://www.leepa.org)

October 16, 2025

10231180

TURNER ADRIENNE  
17226 WILLOW WOOD DR  
STRONGSVILLE, OH 44136

**Re: 2022 Tax Roll Value & FEMA 50% Rule**

12 FAIRVIEW BLVD FORT MYERS BEACH 33931  
34-46-24-W4-00400.0060

In the chart below you will find the most recent values from the 2022 ad valorem tax roll. These values represent the Lee County Property Appraiser's determination of Just Value for ad valorem tax purposes.

	<b>JUST VALUE</b>
Total Value	\$586,753
Land Value	\$226,700
Land Extra Features Value	\$0
Building Value	\$300,276
Building Extra Features Value	\$59,777

Further, the FEMA 50% rule calls for the use of "market value" in determining "substantial improvement" and the Lee County Commission has adopted a definition of market value which includes "...or tax assessment value adjusted to approximate market value by a factor provided by the Property Appraiser...", and the "Building Value" listed above will likely meet the needs of most owners. Please note that these are allocated values, developed as of January 1, 2022, and they may not reflect the current value of your property. If you believe that our conclusions and methods are not useful for your purposes, I encourage you to consult an independent professional.

Please be advised that we are providing this information as a proactive courtesy and this letter serves as an official copy of our records for the parcel listed above as of the effective date of this letter. I hope this letter is helpful to you as you evaluate the process of recovering from the impacts of Hurricane Ian.

Sincerely,

Hon. Matthew H. Caldwell



Owner Acknowledgement

This page is required for ALL Building Permit Applications

ACKNOWLEDGEMENT OF TOWN OF FORT MYERS BEACH REGULATIONS BY OWNER OR AUTHORIZED AGENT OF OWNER

NOTICE OF ADDITIONAL RESTRICTIONS: In addition to the requirements of this permit, there may be additional restrictions applicable to this property that maybe found in the public records of this County, and there may be additional permits required from other governmental entities such as the Water Management District, State agencies, or Federal agencies. I acknowledge that any demolition or renovation of an existing structure must comply with Florida Statutes s. 469.003, Florida Building Code, and any other relevant regulations, including state and federal law. I understand that I am responsible for notifying the Department of Environmental Protection in advance of any intentions to remove asbestos, when applicable, in accordance with state and federal law.

WARNING OF WORK IN THE COUNTY RIGHT-OF-WAYS: This permit does not authorize construction or installation of any structure or utility, above or below ground, within any right of way or easement reserved for access, drainage or utility purposes. This restriction specifically prohibits fencing, sprinkler systems, landscaping other than sod, signs, water, sewer, cable and drainage work therein. If such improvements are necessary, a separate permit for that purpose must be obtained from the Building Department.

INSPECTIONS: This permit is void if the first inspection is not made within six (6) months from the date issued or if no inspection has been made for a period of six (6) months from the most recently passed inspection. The permit is void if the zoning classification is violated. Applicant agrees to comply with the sanitary regulations and understands that the proposed structure may not be used or occupied until an approved certificate of occupancy is issued. Applicant further understands that failure to obtain permit or misrepresentation of the improvements is a misdemeanor and upon conviction, applicant can be punished as provided by the law. Failure to comply with the mechanics lien law can result in the property owner paying twice for improvements

NOTICE OF CLEARING RESTRICTIONS: Issuance of a Demolition Permit for a structure does not authorize removal of vegetation beyond the footprint of the structure. A Demo Permit is not a clearing permit.

WORK IN THE SPECIAL FLOOD HAZARD AREA: Be advised that Substantial Damage/Substantial Improvement requirements will apply to structures located in the Special Flood Hazard Area with Finished Floor Elevations below the Base Flood Elevation.

CERTIFICATION: Application is hereby made to obtain a permit to do the work and installations as indicated. I, THE OWNER OR AUTHORIZED AGENT OF OWNER, certify that I have not performed any work or installation prior to the issuance of a permit and that all work will be performed to meet the standards of all laws regulating construction in this jurisdiction. The permit or application fee may have additional fees imposed for failing to obtain permits prior to commencement of construction. The permit application or approved permit expires if work is not commenced within 180 days from the date of issuance. I, THE OWNER OR AUTHORIZED AGENT OF OWNER understand that the structure cannot be used or occupied until a certificate of occupancy is issued. By signing this permit application, I, THE OWNER OR AUTHORIZED AGENT OF OWNER, agree that I have been retained by the property owner to provide contracting services for the trade for which I am listed. Furthermore, it is my responsibility to notify the Building Plan Review and Inspection Division should I no longer be THE OWNER OR AUTHORIZED AGENT OF OWNER responsible for providing said contracting services. I, THE OWNER OR AUTHORIZED AGENT OF OWNER, agree that I understand the review and issuing of this permit does not exempt me from complying with all State and local County Codes and Ordinances.

NOTICE OF COMMENCEMENT INFORMATION Per Florida Statutes 713.135 a Notice of Commencement (NOC) is required for construction of improvements totaling more than \$2,500, with certain exceptions. For A/C Repairs or Replacements a notice of commencement is required for improvements more than or equal to \$15,000. The applicant shall file with the issuing authority prior to the first inspection either a certified copy of the recorded NOC or a notarized statement that the NOC has been filed for recording, along with a copy thereof. In order to comply with the state requirement, permits will be placed in inspection hold until proof of the NOC is filed with the building permitting and inspection department. The issuing authority shall not perform or approve subsequent inspections until the applicant files by mail, facsimile, hand delivery, email or any other means such as certified copy with the issuing authority.

WARNING TO OWNER: YOUR FAILURE TO RECORD A NOTICE OF COMMENCEMENT MAY RESULT IN YOUR PAYING TWICE FOR IMPROVEMENTS TO YOUR PROPERTY. A NOTICE OF COMMENCEMENT MUST BE RECORDED AND POSTED ON THE JOB SITE BEFORE THE FIRST INSPECTION. IF YOU INTEND TO OBTAIN FINANCING, CONSULT WITH YOUR LENDER OR AN ATTORNEY BEFORE RECORDING YOUR NOTICE OF COMMENCEMENT.

Job Street Address: 12 Fairview Blvd

Signature of Property Owner

Adrienne Turner
Typed or printed name of Property Owner

STATE OF Ohio COUNTY OF Cuyahoga

The foregoing instrument was certified and subscribed before me by means of physical presence OR online notarization, this 10th day of Oct, 2025, by Adrienne Turner who is personally known to me OR who has produced Ohio DL as identification.

Notary Public Signature



KOURTNEY THOMAS
NOTARY PUBLIC - OHIO
MY COMMISSION EXPIRES 08-11-29

If An Owner Agent is Being Named, Please complete below

I, (Property Owner), hereby certify that is my authorized AUTHORIZED AGENT/representative of the property described herein. All answers to the questions in this registration and any supplementary information attached to and made part of this registration is honest and true.

02/06/24



**PLEASE NOTE:**

- Mailed in or paper plans will not be accepted.
- Submit all corrections together at one time with an appropriate response/ cover letter showing where each corrected item can be found to [resubmittal@fmbgov.com](mailto:resubmittal@fmbgov.com).
- Please note that no other reviews will be done until the **Zoning Review** is approved.
- Resubmittals will not be processed unless all review comments are addressed.

Please refer to the **Permit Portal** to access a copy of this rejection letter.

Sincerely,

Town of Fort Myers Beach Building Services and Community Development Departments.





REPAIR/IMPROVEMENT COST FORM

CONTRACTOR'S AFFIDAVIT

I hereby attest that I have personally inspected the building located at the above-referenced address and discussed the nature and extent of the work requested by the owner, including all improvements, rehabilitation, remodeling, repairs, additions and any other form of improvement.

At the request of the owner, I have prepared a cost estimate for all of the improvement work requested by the owner and the cost estimate includes, at a minimum, the cost elements identified by the Town of Fort Myers Beach that are appropriate for the nature of the work. If the work is repair of damage, I have prepared a cost estimate to repair the building to its pre-damage condition. I acknowledge that if, during the course of construction, the owner requests more work or modification of the work described in the application, that a revised cost estimate must be provided to the Town of Fort Myers Beach, which will re-evaluate its comparison of the cost of work to the market value of the building to determine if the work is substantial improvement. Such re-evaluation may require revision of the permit and may subject the property to additional requirements.

I also understand that I am subject to enforcement action and/or fines if inspection of the property reveals that I have made repairs or improvements that were not included in the description of work and the cost estimate for that work that were the basis for issuance of a permit.

Adrienne Turner
Contractor's Signature

Adrienne Turner
Print Name

11/18/25
Date

State of Ohio

County of Cuyahoga

Before me this 18th day of November, 2025, personally appeared Adrienne Turner who being duly sworn deposes and says that he/she has read, understands and agrees to comply with all the aforementioned conditions.

[Signature]
Signature, Notary Public

Kourtney Thomas
Print Name, Notary Public





Dec 18, 2025 10:39:28 AM



Dec 18, 2025 10:39:35 AM



Dec 18, 2025 10:39:38 AM

CODE COMPLIANCE SPECIAL MAGISTRATE  
THE TOWN OF FORT MYERS BEACH, FLORIDA

TOWN OF FORT MYERS BEACH,  
a Florida municipal corporation,

FMB Case No. 20250853

Petitioner,

vs.

ADRIENNE TURNER,

Respondent.

\_\_\_\_\_ /

ORDER OF COMPLIANCE AND TAXATION OF COSTS

THIS CAUSE came before the undersigned Administrative Law Judge, John G. Van Laningham, serving as the Special Magistrate for the Town of Fort Myers Beach (“Special Magistrate”), on January 6, 2026, regarding work without required permits at the property located at 12 Fairview Blvd, Fort Myers Beach, Florida, as reflected on the duly-noticed Agenda for that date, and as addressed during the Status Update (Fines Assessments) portion of the hearing. The Town presented evidence and representations concerning the compliance status of the case. Based upon the record made at hearing, it is hereby,

ORDERED AND ADJUDGED:

1. Respondent was previously found in violation and was provided until December 3, 2025, to obtain the required building permits, with a daily fine of \$250.00 to accrue for noncompliance thereafter.
2. The Town’s evidence and representations established that the required permits were obtained on December 12, 2025, and that an affidavit of compliance was thereafter filed reflecting a compliance date of December 12, 2025; accordingly, Respondent brought the property into compliance after the compliance date identified in the prior Order, but prior to the January 6, 2026, status-update hearing.
3. Although a daily fine would otherwise have accrued after December 3, 2025, the Town requested, and the Special Magistrate finds it appropriate, that any fine which otherwise would have accrued during the brief interval between the compliance deadline and the

established compliance date shall be waived; therefore, no daily fine is assessed in this matter.

4. Respondent is ordered to pay administrative costs in the amount of \$250.00 to the Town of Fort Myers Beach.

DONE AND ORDERED this 8th day of January, 2026.

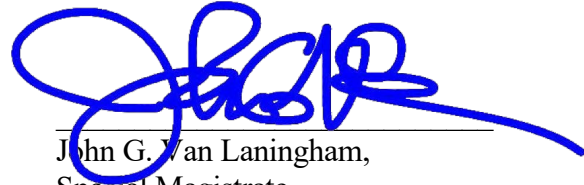

John G. Van Laningham,  
Special Magistrate

CERTIFICATE OF SERVICE

I, the undersigned, hereby certify that a true and correct copy of this Order was sent by U.S. Mail on the 8th day of January, 2026, to:

Adrienne Turner  
17226 Willow Wood Rd  
Strongsville, OH 44136

Amy Baker: [amy@fmbgov.com](mailto:amy@fmbgov.com)

Nancy Stuparich: [nstuparich@voselaw.com](mailto:nstuparich@voselaw.com)

Michael Hauserman: [Michael.hauserman@fmbgov.com](mailto:Michael.hauserman@fmbgov.com)

I certify this document to be a true and correct copy of the original on file in Town Hall, Fort Myers Beach, State of Florida, County of Lee.

BY:   
Amy Baker (Jan 8, 2026 15:18:05 EST)  
Town Clerk and Clerk to the Special Magistrate

DATED: Jan 8, 2026

**APPEAL:** An aggrieved party may appeal an Order of the Special Magistrate of the Town of Fort Myers Beach to the Lee County Circuit Court. The appeal shall be limited to appellate review of the record created before the Special Magistrate. An appeal shall be filed within thirty (30) days of the execution of the Order to be appealed.

PAYMENT OF ADMINISTRATIVE COSTS, LIENS OR FINES: Checks should be made payable to “Town of Fort Myers Beach,” include the case number and mail to:

Town of Fort Myers Beach  
Attention: Code Enforcement  
6231 Estero Boulevard  
Fort Myers Beach, FL 33931